



MAG X

MANUAL



Table of Contents



1: Introduction	page 6
2: Caution	page 7
3. FCC and CE Compliance	page 8
4: Manual Tips	page 9
5: Quick Start	page 10
6: System Highlights	page 12
7: Receiver	page 13
7.1: Specifications	page 13
7.2: Receiver Operation	page 13
7.2.1: Measured Depth vs. Relative Depth	page 14
7.3: Icons	page 15
7.3.1: Main Page Icons	page 15
7.3.2: Secondary Page Icons	page 17
7.3.3: Transmitter Information:	page 18
7.3.4: Calibration & Range Forecasting	page 19
7.3.5: Setup Page Icons	page 19
7.4: Calibration	page 20
7.4.1: Depth Calibration	page 20
7.4.2: Roll Calibration	page 21
7.5: Operation	page 22
7.5.1: Range Forecast	page 22
7.5.2: Transmitter Lock/Unlock	page 23
7.5.3: Transmitter Settings	page 24
7.5.4: Receiver Settings	page 25

Table of Contents



7.5.5: Radio Channel Selection	page 27
7.5.6: Receiver and Display Pairing	page 28
7.5.7: Pitch Unit Selection	page 29
7.5.8: Distance Unit Selection	page 30
7.5.9: Time Setting	page 31
7.5.10: Manual System Lock/Unlock	page 32
7.5.11: Target Speed Control	page 33
7.5.12: Depth Speed Adjustment	page 34
7.6: Receiver Maintenance	page 35
8: Display	page 36
8.1: Display Specifications	page 36
8.2: Display Operations	page 36
8.3: Display Icons	page 37
8.3.1: Main Page Icons	page 37
8.4: Down Hole Frequency Change	page 39
8.5: Radio Telemetry Channel Selection	page 41
8.6: Receiver & Display Pairing	page 42
8.7: Brightness Adjustment	page 43
8.8: Bore Log	page 44
8.8.1: Job Management	page 44
8.8.2: Creating a New Job Profile	page 44
8.8.3: Setting the Rod Lengths	page 45
8.8.4: Data Logging	page 46
8.8.5: Bore Profile	page 47

Table of Contents



8.8.6: Data Point Information Screen	page 47
8.8.7: Generating Reports	page 48
8.9: Device Management	page 49
8.9.1: Automatic Receiver Unlock.....	page 50
8.9.2: Automatic Transmitter Unlock	page 51
8.11: Help	page 52
8.12: Display Maintenance	page 53
9: Transmitter	page 54
9.1: Introduction.....	page 54
9.2: Specifications	page 55-58
9.3: Digital Information	page 59
10: Locating Methods.....	page 60
10.1: Three Point Locating	page 60
10.1.1: The Basics	page 60
10.1.2: Find the Transmitter	page 63
10.1.3: Tracking on the Fly:.....	page 66
10.1.4: Bore-To	page 67
11: Battery and Charger.....	page 68
12: Warranty	page 69



MAG X SYSTEM

This locating system also offers four channel license free radio telemetries between the receiver and remote display. The user can easily “pair” any two receivers and displays so that communications between the “pair” will not be interfered by other “pairs”.

This manual is intended to provide information and instructions on how to use this locating system properly. Underground Magnetics Inc. (UM) reserves the right to improve the locating system and the Operator’s Manual at any time without notice.

1: Introduction

TRANSMITTER

The Transmitter (sometimes referred to as a Sonde or Beacon) sends digital information of the transmitters pitch, roll, temperature and battery status through an FM modulated RF signal.

RECEIVER

The Receiver receives this information and uses RF Signal to identify the transmitter's

DISPLAY

The Display— the Receiver transmits the locating information to the remote display through a radio telemetry system.

A horizontal directional drilling machine operator can use the information from the display to the guide the drill head to the desired location.



2: Caution



The operator must understand safety procedures and correct operation methods before operating the HDD and the locating system.



HDD machines can cause property damage and personal injury upon striking underground power lines, gas lines, phone lines, television cables, fiber optic cables, or sewage lines. Make sure to confirm by uncovering and marking all underground utilities before crossing.



Do not use the locating system near flammable or explosive substances.



Wear proper personal protective equipment including steel-toed boots, safety gloves, helmets, reflective vests, and safety goggles.



Obey all local safety regulations.



This locating system is only a tool to assist the operator to locate the drill head. It is the operator, not the Mag locating system that is responsible for identifying the drill head location. UM is not responsible for any damage or loss caused by using the Mag system. Operators should operate the Mag system according to the manual.



If there are any questions, please contact UM at support@undergroundmagnetics.com or call customer service at (515) 505-0960

3: FCC and CE



This device complies with Part 15 of the FSS Rules. Operation is subject to the following two conditions:

- ◆ This device may not cause harmful interference, and
- ◆ This device must accept any interference received, including interference that may cause undesired operation.



Changes or modifications not expressly approved by Underground Magnetics Inc. will void the user's authority to operate equipment.



Note: This product has been tested and found to comply with the limits for a Class B digital device, pursuant to Part 15 of the FCC Rules. These limits are designed to provide reasonable protection against harmful interference in a residential installation. This product generates, uses and can radiate radio frequency energy, and if not installed and used in accordance with the instructions, may cause harmful interference to radio communications. However, there is no guarantee that interference will not occur in a particular installation. If this product does cause harmful interference to radio or television reception, which can be determined by turning the equipment off and on, the user is encouraged to try to correct the interference by one or more of the following measures:

- ◆ Reorient or relocate the receiving antenna .
- ◆ Increase the separation between the equipment and the receiver.
- ◆ Connect the equipment into an outlet on a circuit different from that to which the receiver is connected.
- ◆ Consult the dealer or an experienced radio/TV technician for help.



This system is classified as Class 2 radio equipment per the R & TTE Directive and may not be legal to operate or require a license to operate in some countries. The list of restrictions and the required declarations of conformity are available in the "resources" section of the UM website.

4: Tips for Reading this Manual

Here are some points to keep in mind as you read through the Mag X Operator's Manual.

Page References

This question mark and textbox will tell you the page in the Operator's Manual where you can find more detailed information on the corresponding topic.



- ➔ The following two pages contain a short preface. This will be a quick introduction to the steps in which you will most likely use your Mag System. It will also contain page references for the later sections of the manual that contain more detailed information for the corresponding steps.
- ➔ The rest of the manual will contain detailed sections that follow the order of the Mag X Receiver and the Mag X menu screens.
- ➔ It is recommended to read the entire Operator's Manual before use.
- ➔ Throughout this manual there will be scannable QR codes that link to our training videos. Be sure to check those out for additional details!



5: Quick Start

1

Turn on receiver by holding power button until Mag logo is visible on screen.



Page 14

2

Walk bore-path and use range forecasting to check for interference and select frequency.



Page 22

3

Install batteries into transmitter. Install battery cap with provided battery cap tool.

4

Turn on display by holding power button until Mag logo is visible on the screen.

5

Install transmitter into the housing.

6

Check Calibration by placing receiver (10ft/3m) away from housing, measured from inside edge of receiver to the center of the housing.



Page 20

5: Quick Start

7

If distance on receiver's screen reads anything other than (10ft/3m) perform calibration.

8

Choose locating mode either Single Point or Single Target.



Page 63

9

Locate FNP (Front Null Point).



Page 64

10

Locate RNP (Rear Null Point).



Page 64

11

Locate LL (Locate Line).

Repeat steps 9 through 11 as you continue to guide the drill.



Page 64

6: System Highlights

Mag X System

- ➔ High Precision and high anti-interference Faraday shield 3D antenna structure.
- ➔ High-performance DSP
- ➔ Dual locating system, functioning as two receivers independently tracking to provide better accuracy and reliability
- ➔ Locating Method—choose Single Point or Single Target Mode
- ➔ Display features 7" color touch screen
- ➔ Display features a Built-in Data Logging System



Receiver : Mag X COR/PRO

Display : Mag X

Mag X COR Transmitters:

ECHO 50XF ECHO ST ECHO XMINI

Mag X PRO Transmitters:

ECHO 110 ECHO ST ECHO XMINI

ECHO 90 ECHO 70

ECHO 50XF ECHO 75XF





7: Receiver

7.1: Specifications



16 System frequencies	.325kHz – 41kHz
Water resistant	IP65
Temperature range	-4° to 140°F (-20° to 60°C)
Telemetry	4 radio channels with range up to 3000ft (900m)*
Rechargeable lithium battery	12.5V
Battery life	Up to 50 hours
Dimensions	29" x 9" x 13" (73.5cm x 23cm x 33cm)
Weight	8.5lbs (3.85kg)

7.2: Receiver Operation

-  Power key
 - * Press and hold to turn on or off
-  Up key
 - * In the menu, move to previous cursor selection.
 - * From main page, tap to switch between relative depth and measured depth. **See page 14**
-  Down key
 - * In the menu, tap to move to next cursor selection.
 - * From main page, tap to record Bore data. **See page 43**
-  Confirm key
 - * Tap to confirm cursor selection.
 - * Press and hold to enter secondary page.
 - * Tap from main page to enter Bore-To mode.
-  Setup key
 - * Tap to enter calibration page/return to main page.
 - * Press and hold to enter the menu screen.

* With optional Yagi Antenna

7: Receiver

7.2.1: Measured Depth vs. Relative Depth

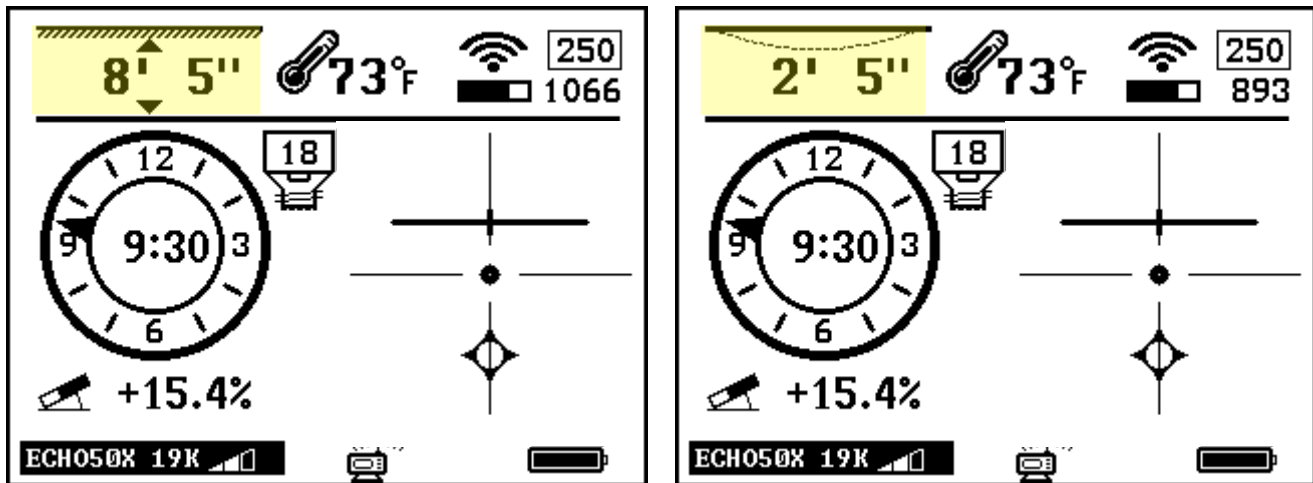

1. From the main locating screen, tap  to switch between Measured Depth and Relative Depth as highlighted above.

This feature is only available when recording Bore-Log data.

See Page 43 for Bore-Log instructions



- * **Measured Depth** - This is the measured distance between the locator and the transmitter located inside the drill head.



- * **Relative Depth** - This information is measured based on the pitch of the transmitter/housing.
- * This measurement is the depth of the transmitter/housing in relation to the starting point of the bore.

In this example, the transmitter is 2'5" deep in relation to where the first data point was recorded at the start of the bore.

7: Receiver

7.3: Icons

7.3.1: Main Page Icons

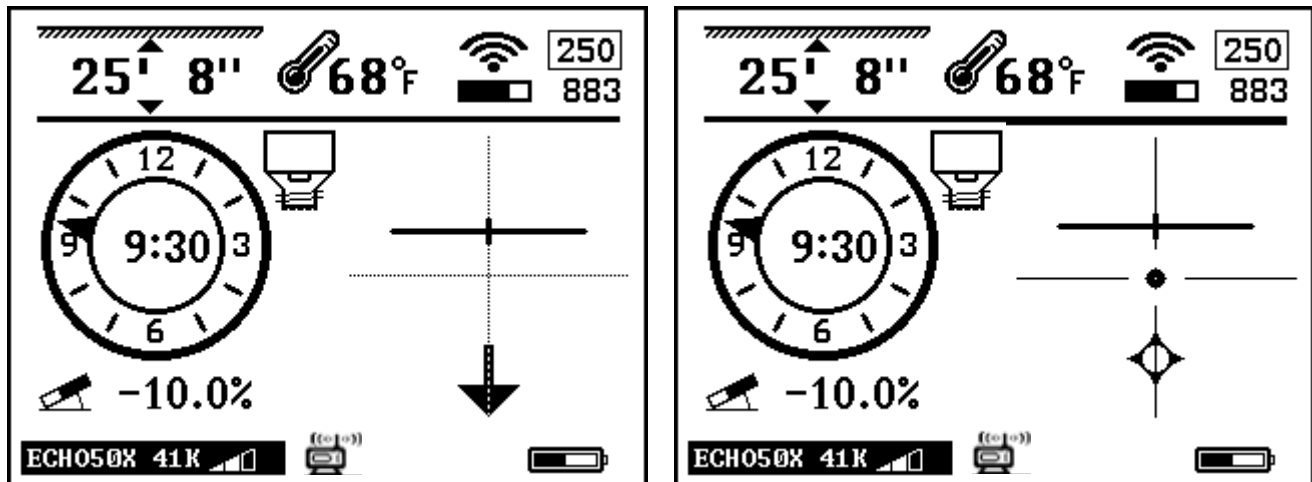

250

→ Signal to Noise Ratio

883

→ Signal strength

ECHO50X 41K

→ Transmitter model, frequency, and power



→ Visual representation of signal to noise

68°F

→ Transmitter temperature (flashing indicates the transmitter is overheating)

25' 8''

→ Depth when over the head



→ Receiver remote telemetry indicator



→ Rod Counter

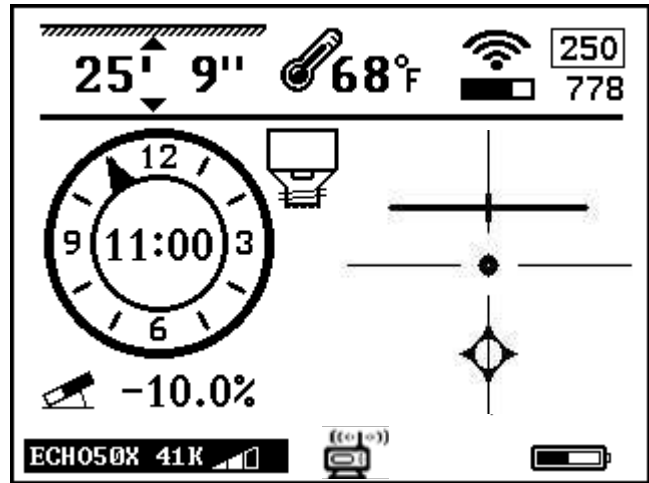
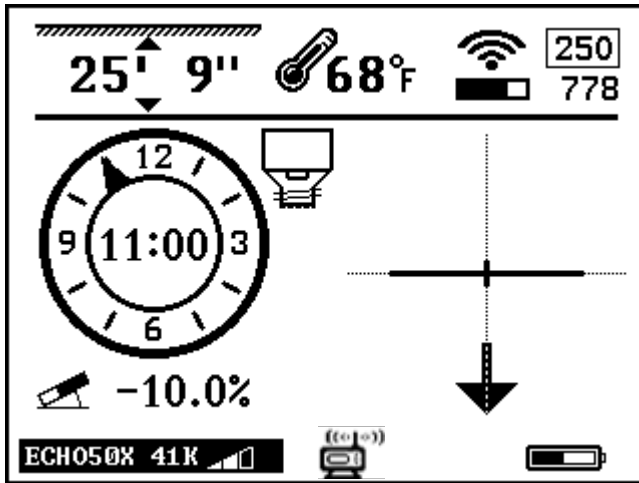

Roll Indicator



Clock Positions



Locate Line

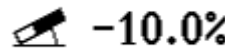

Pitch



Single Point

→ Direction of nearest Null Point →

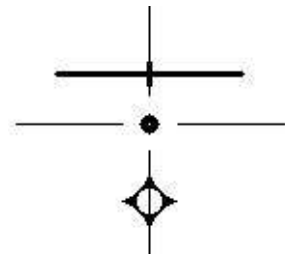

Single Target

B26 	B8 	B23
B28 	B29 	

To select locating modes see section **10.1.1**

7.3.2: Secondary Page Icons

To enter the secondary Page, press and hold 

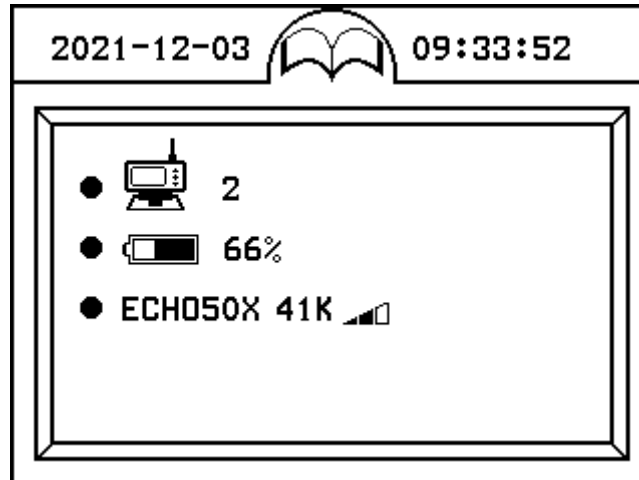

2



Radio Channel



66%



Receiver Battery Status

ECH050X 41K 





Transmitter Model,
Frequency and Power

Tap  to view transmitter information.

7.3.3: Transmitter Information Page

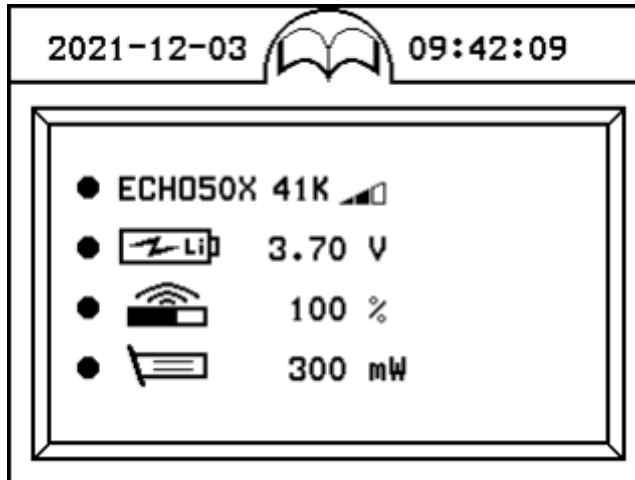
From secondary page, tap  to view transmitter information page.



ECH050X 41K 

Transmitter Model, Frequency and Power level

 Li 3.70 V

Transmitter battery voltage meter

 100 %

Transmitter antenna health.
(Normal range 95% to 105%)

 300 mW

Transmitter Housing suitability.

Note:

Normal Power Mode below 800mW
High Power Mode below 3000mW
(Numbers above mW will see lower battery life).

Tap  to view transmitter information.

7.3.4: Calibration and Range Forecast Page Icons

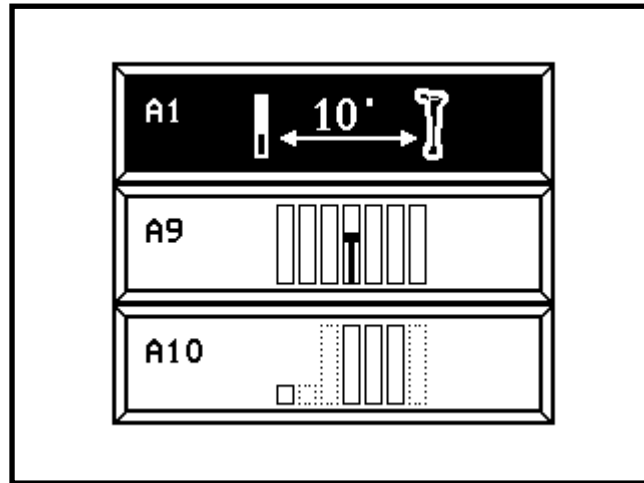

A1: 10ft Calibration

A8: Range Forecast

7.3.5: Setup Page Icons

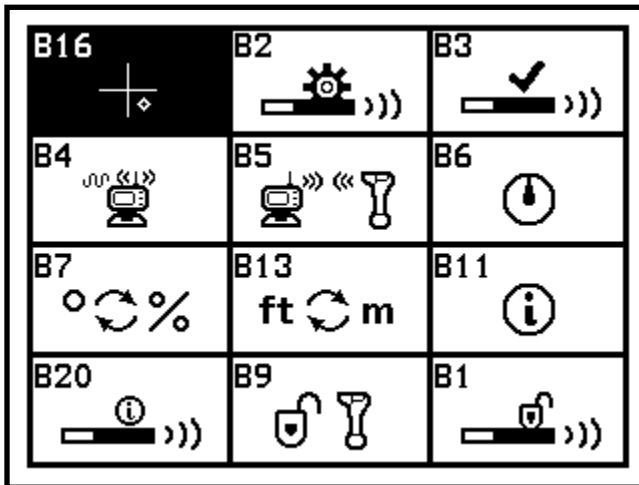

B1: Transmitter lock/unlock

B2: Transmitter settings

B3: Receiver settings

B4: Radio channel selection

B5: Receiver and Display pairing

B6: Roll calibration

B7: Pitch and unit selection

B8: Time setting

B9: System lock/unlock

B11: System information

B13: Distance and unit selection

B16: Speed Control

B20: Transmitter Information

B23: Locating Mode

B26: Depth Speed

B28: Directional Line

B29: Locate Line

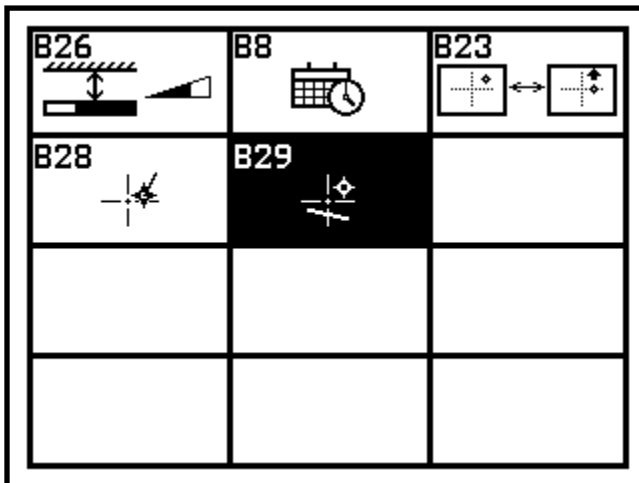

7.4: Calibration

7.4.1: Depth Calibration





Warning: Do not calibrate around strong active or passive interference. For example, don't calibrate around an electrical transformer (active), or on concrete with rebar and/or wire mesh (passive). These types of areas can affect the depth calibration and accuracy significantly.

1. Place transmitter inside the housing flat on the ground.
2. Measure from the center of the housing, 10' to the inside edge of the locator.

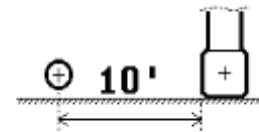
3. Tap  to enter calibration screen.



4. Tap  to enter the 10' calibration page (A1)

5. Tap  twice more to begin calibration.

A check mark will show when calibration is complete.

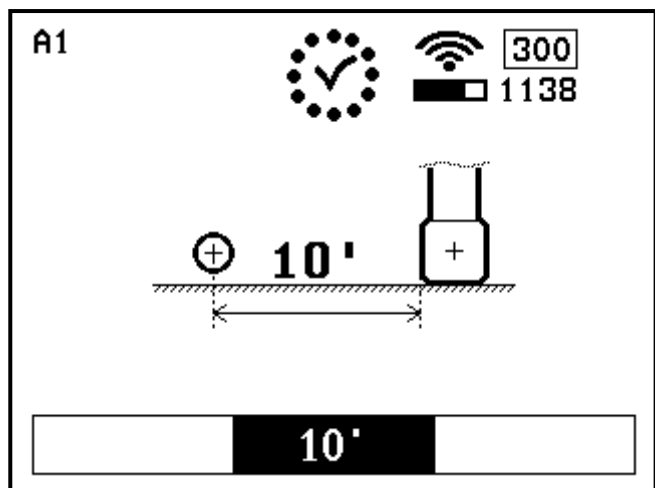
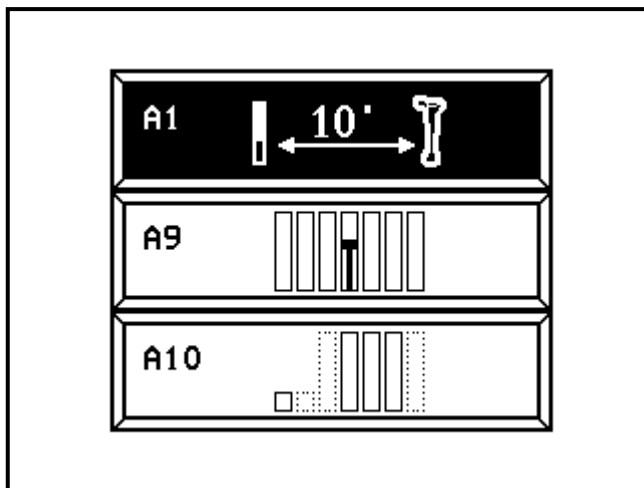

7.4.2: Roll Calibration

1. Place transmitter housing in a 12 o'clock position.

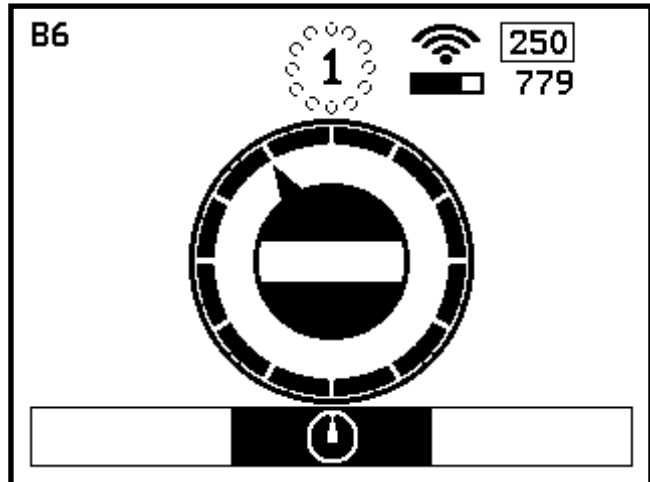
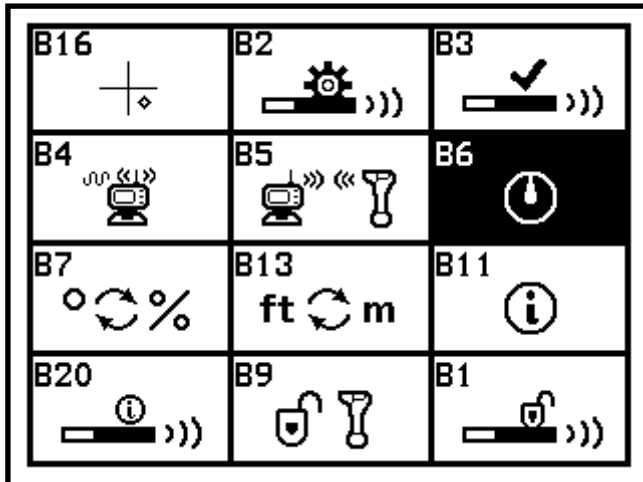

1. Press and hold to enter Setup page
2. Tap to Select B6 icon.
3. Tap to enter Roll Calibration Page.

4. Tap or until the arrow is in the 12 o'clock position,
5. Tap twice to start roll calibration and wait for calibration to complete.

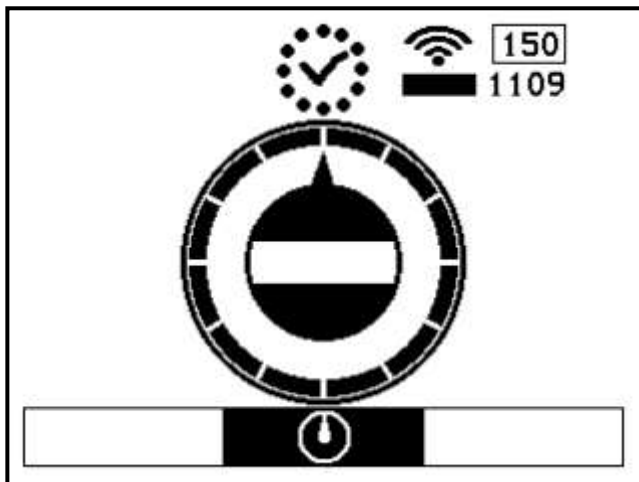

6. Calibration Complete.

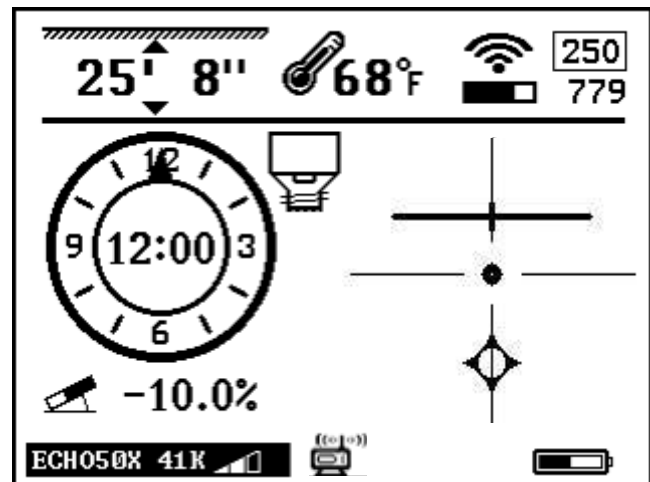

7. Tap to return to Main Page

7.5: Operation

7.5.1: Range Forecast during Pre-Bore Walk

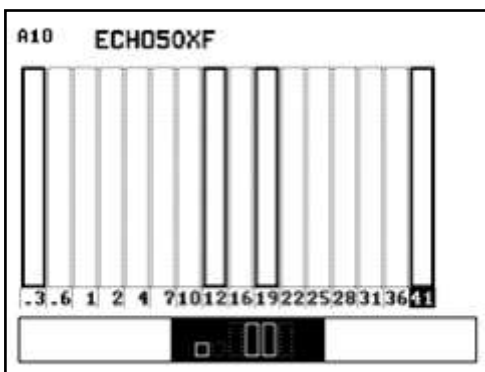
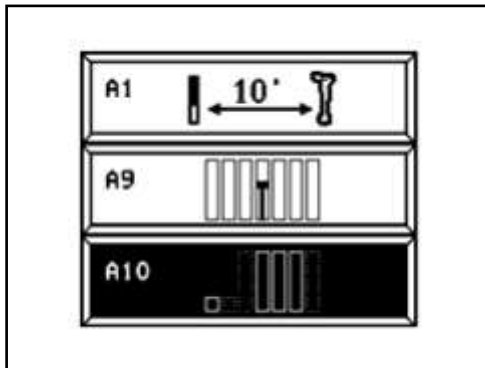
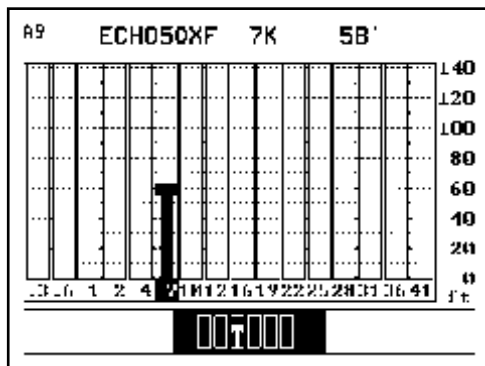
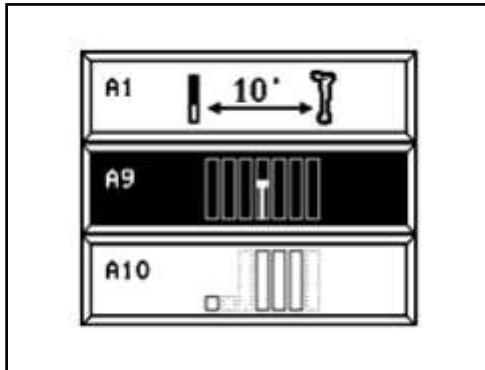

Range Forecast

1. Tap to enter calibration page then tap to select A9. Tap to enter the Range Forecast page. (The X-axis shows the available frequencies)
2. To check each frequency, tap to move to the next frequency. (A line as well as a predicted range will appear showing the range forecast for the selected frequency in that area.)
3. Continue tapping to view the range forecast of each available frequency.
4. Press to exit the Range Forecast page and return to Main page.

New Feature! Frequency Selection

1. Tap to enter calibration page then tap to select A10.
2. Tap to enter the Frequency Selection page.
3. Tap or then to select specific frequencies that you would like to scan.
 Solid Line: Frequencies Selected
 Dashed Line: Frequencies Not Selected.
4. Tap to enter to the Range Forecast page (A9).
5. Follow Range Forecast steps 1-4 listed above.

7.5.2: Transmitter Lock/Unlock

Auto Unlock

Page 49

(Start Process within 60 min of placing the batteries the transmitter)

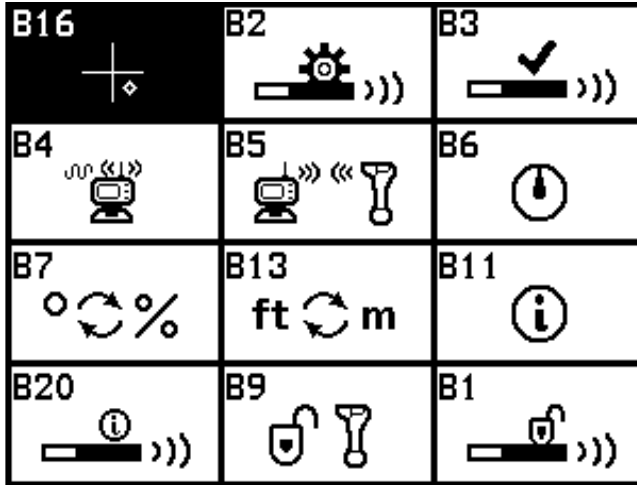

1. Press and hold to enter Setup Page.

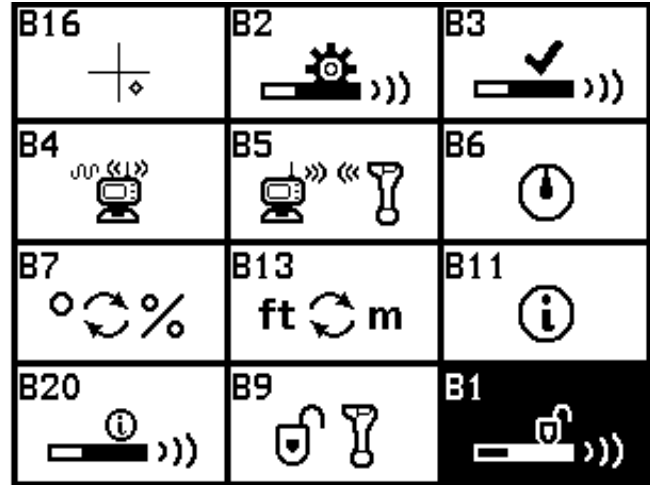

2. Tap to scroll through the page options until B1 is highlighted.

3. Tap to enter Transmitter Lock/Unlock Page.

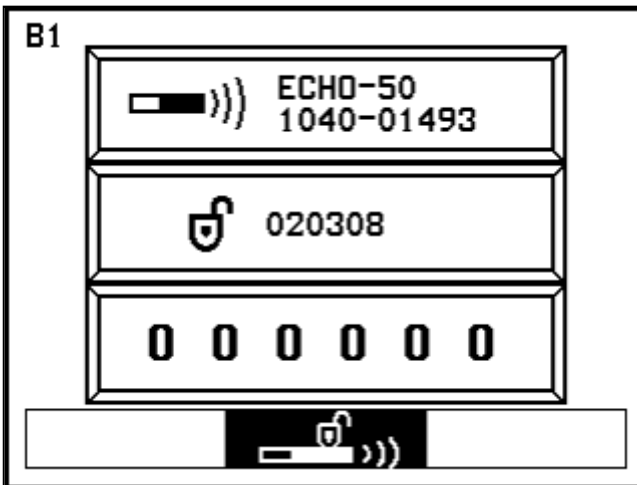

4. Send the Transmitter ID and the Prompt Code to the dealer.

Transmitter ID: 1040-01493

Prompt Code: 020308

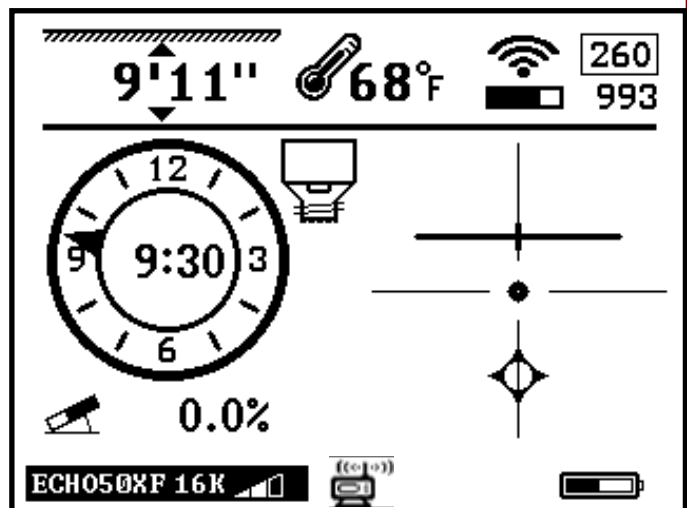

5. Tap to return to Main Page.

The dealer will give you an activation password. Use and to input a number. Tap to move to the next number spot. Tap once done to confirm.

7.5.3: Transmitter Settings

(Start Process within 60 min of placing the batteries the transmitter)

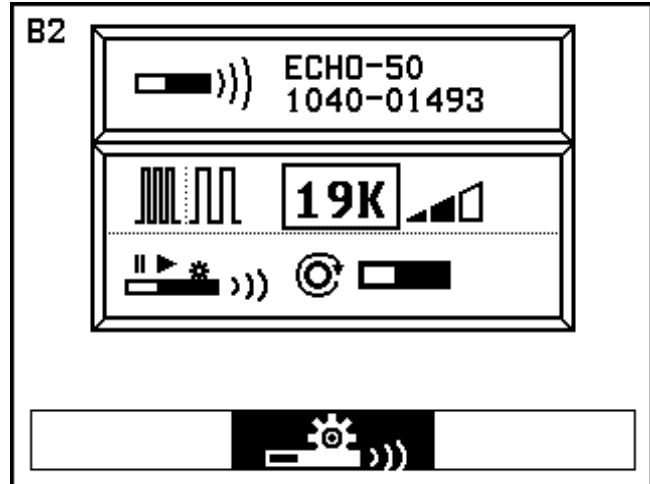
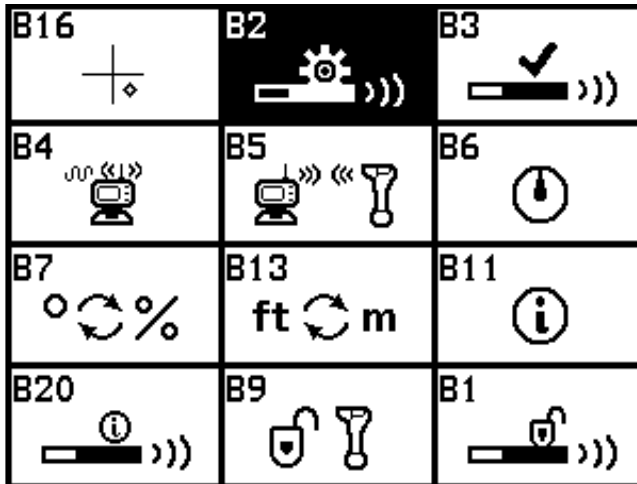

1. Press and hold to enter Setup Page.
2. Tap to select B2.
3. Tap to enter Transmitter Settings Page. Receiver and Echo transmitter will automatically pair.

4. Tap or and to select frequency and power level.
5. Tap to highlight Wake Up Mode and tap to enter.
6. Tap or to select desired mode as described below.

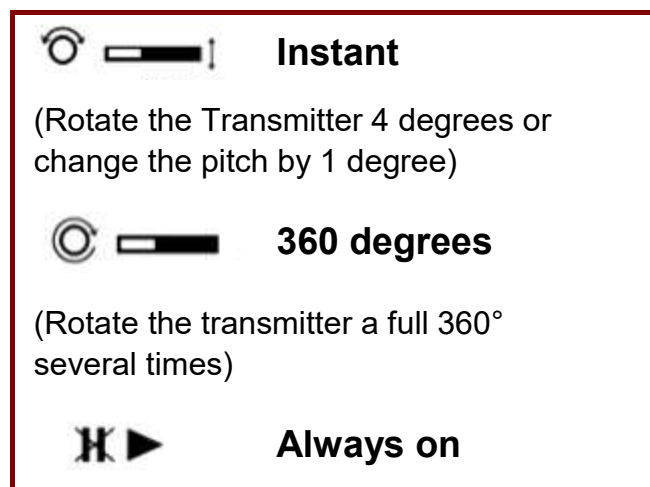
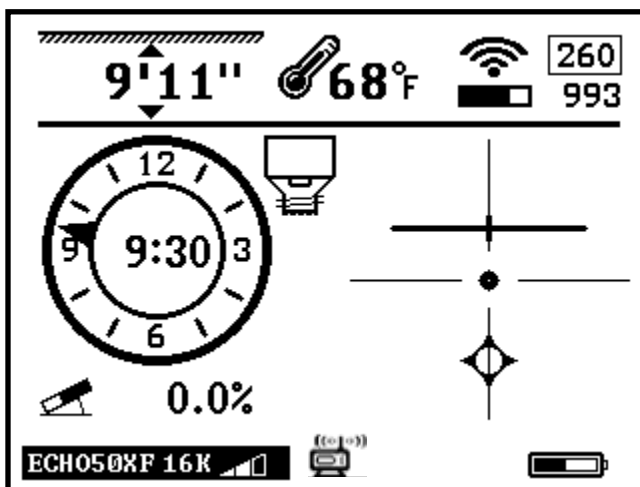

7. Tap to return to Main Page.

7.5.4: Receiver Settings

(This sets the Receiver to look for what type of transmitter and at what frequency.)

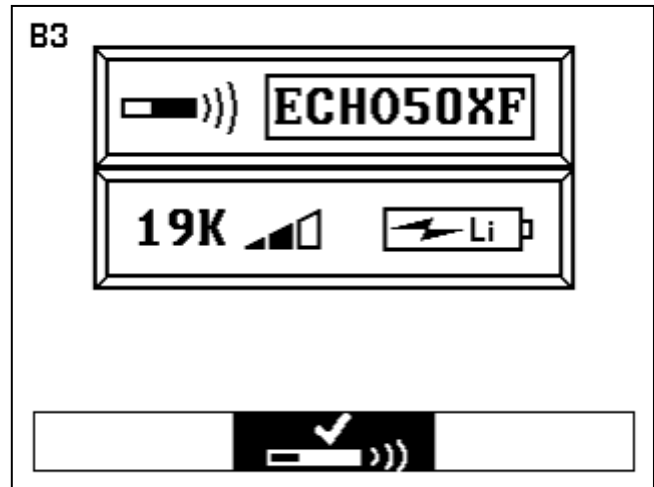
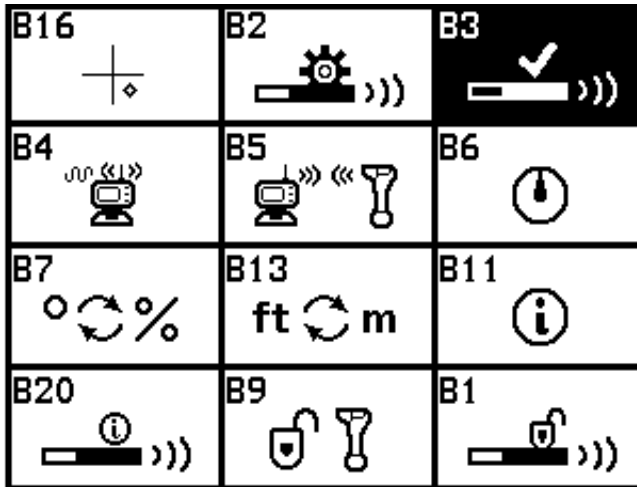

1. Press and hold to enter Setup Page.
2. Tap to select B3.
3. Tap to enter Receiver Settings Page.

4. Tap or and to select transmitter model, frequency, power and battery select.

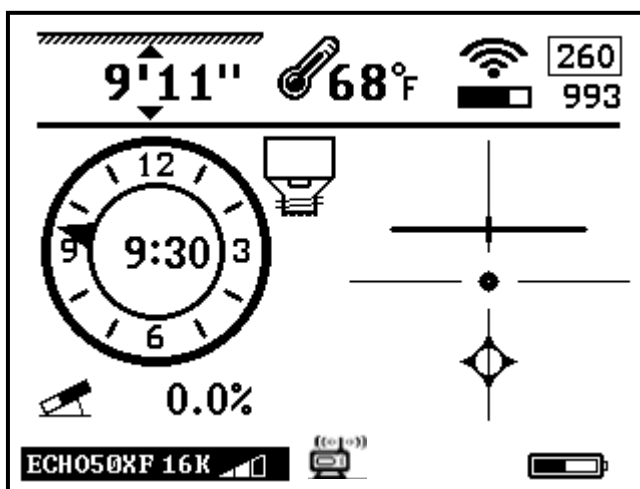



5. Tap to return to Main Page.



7.5.4: Continued

B3 allows for adjustments in the locator **but not the transmitter**.

From this page, you will be able to change the frequency of the locator, the power level and select which battery type.

Battery setting allows the transmitter battery indicator to display the remaining battery life.

When using a primary cell,  the indicator will show full  until the battery is almost completely dead. This is a function of the chemistry of the battery which will not allow metering.

When using a rechargeable Echo Cell battery,  the meter will show full when completely charged at 4.2V. The battery will show as it meters down  until the voltage is 3.4 V (roughly 50 hours in normal power) at which time the indicator will start to flash. This is an indication that the battery needs to be recharged. Users should consider replacing Echo Cell battery every 6 to 12 months depending on the ground conditions.

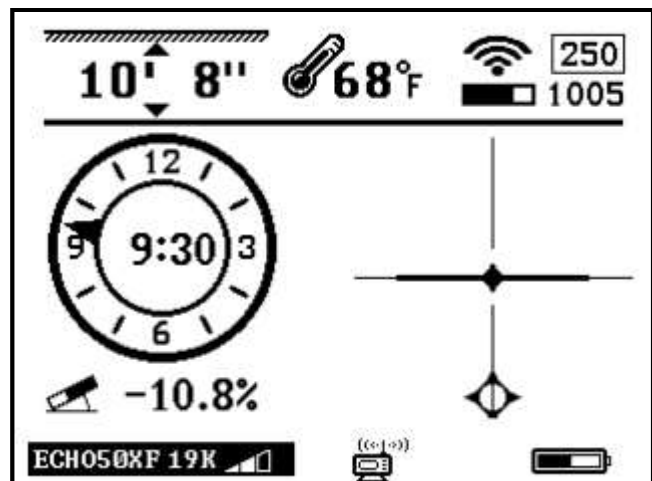
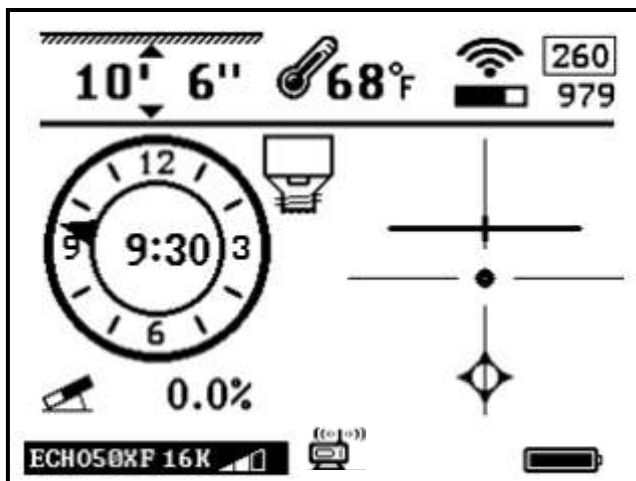

7.5.5: Radio Channel Selection

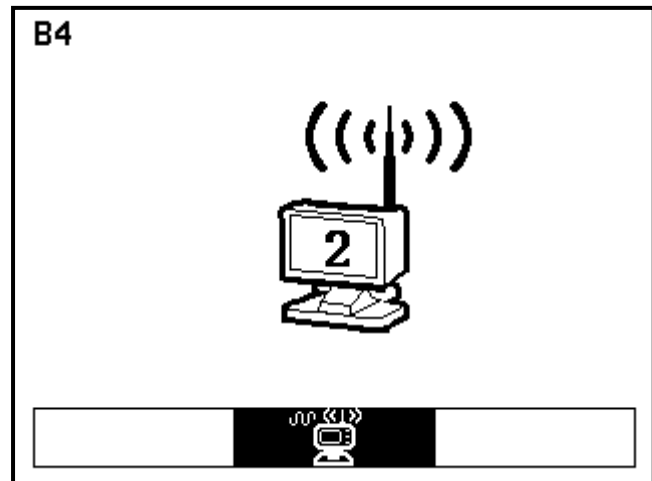
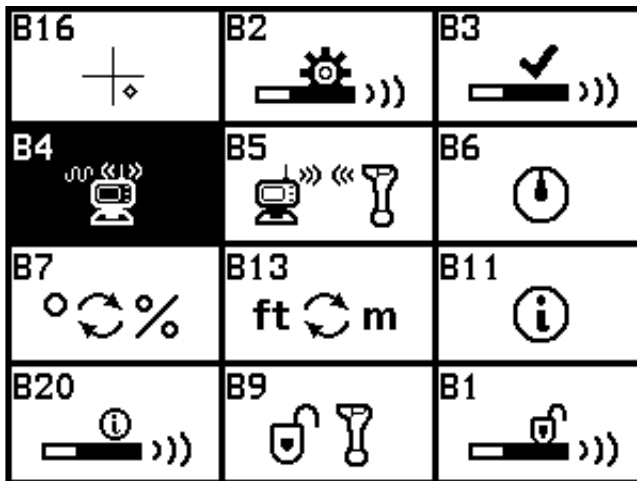

1. Press and hold to enter Setup Page.

2. Tap to select B4.

3. Tap to enter Radio Channel Page.

4. Use or to select radio channel.

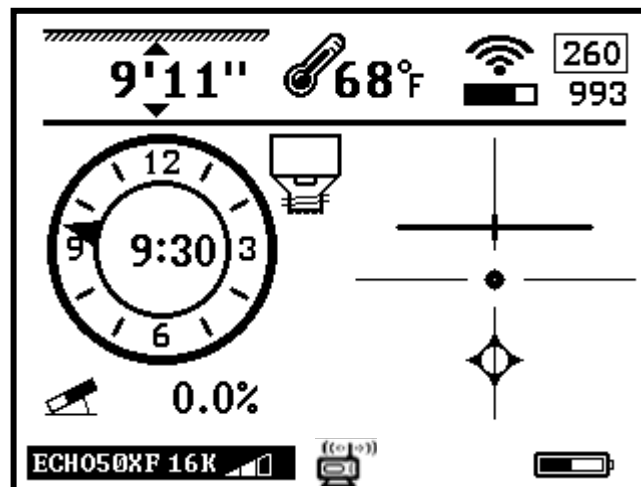

5. Tap to return to Main Page.

7.5.6: Pairing

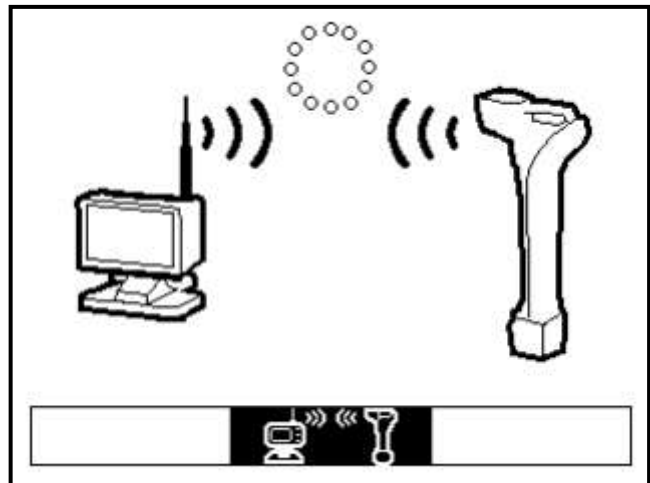
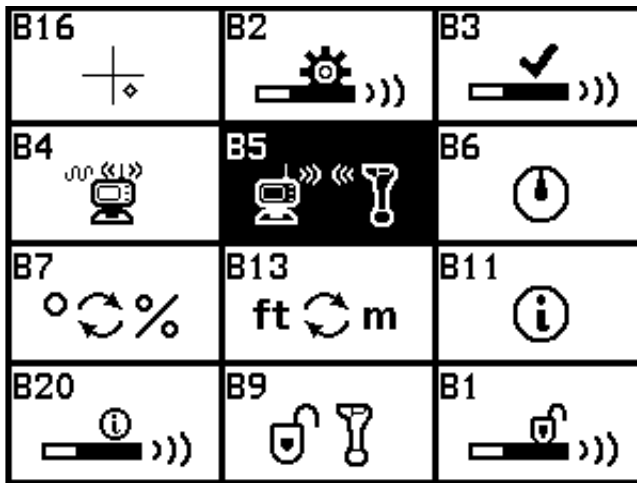

1. Press and hold to enter Setup Page.
2. Tap to select B5.
3. Tap to enter Pairing Page.

4. Tap to start pairing. (it is required that these two steps are performed on the Receiver and Display at the same time.)

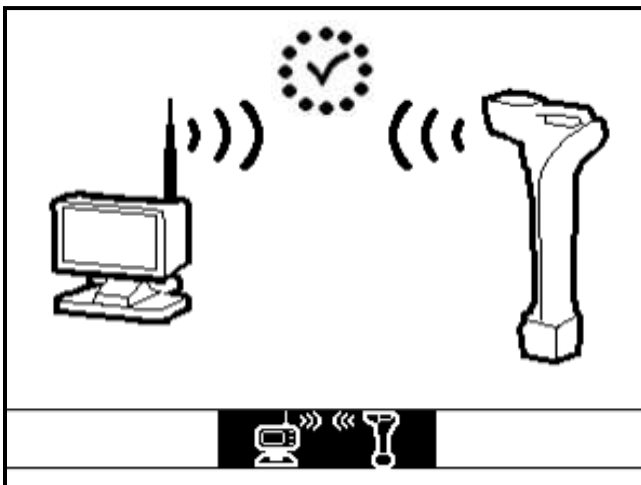

5. Pairing is complete when a check mark appears above.

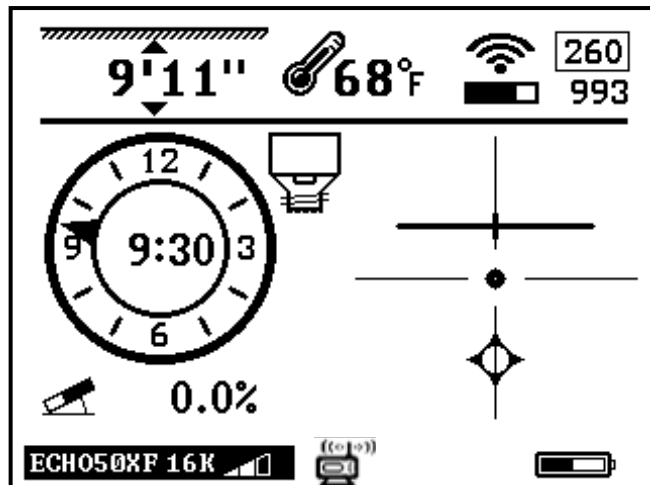

6. Tap to return to Main Page.

7.5.7: Pitch Unit Selection

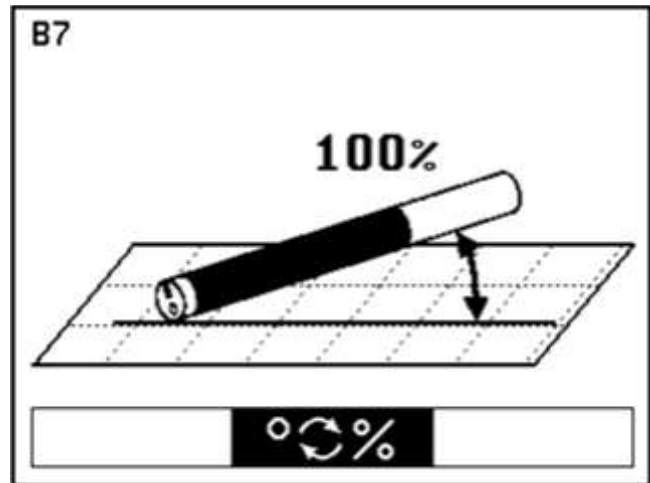
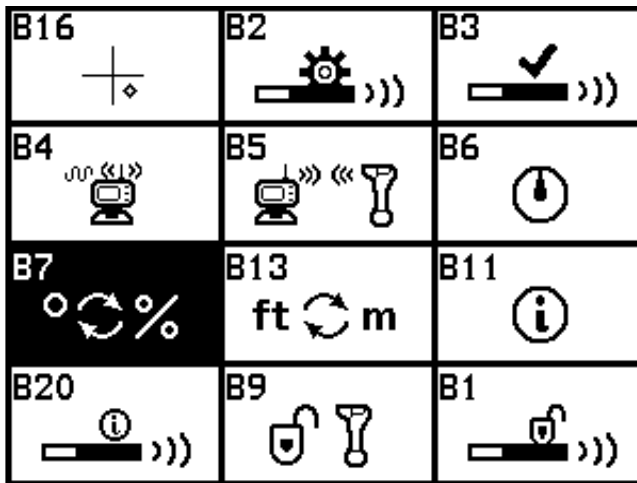

1. Press and hold to enter Setup Page.

2. Tap to select B7 icon.

3. Tap to enter Pitch Unit Selection Page.

4. Tap to switch pitch unit between degrees and percent.

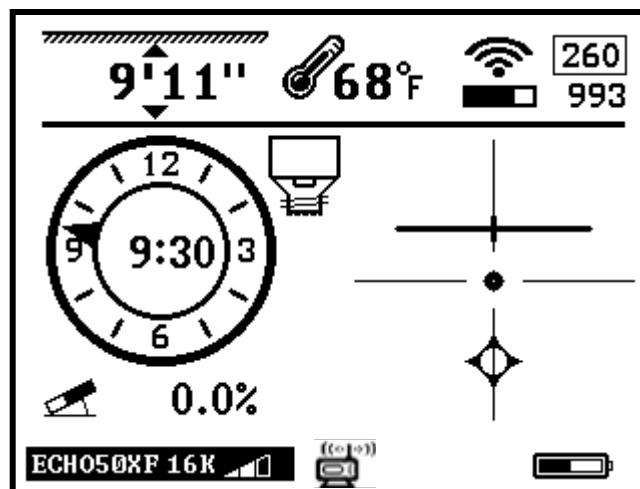

5. Tap to return to Main Page.

7.5.8: Distance Unit Selection

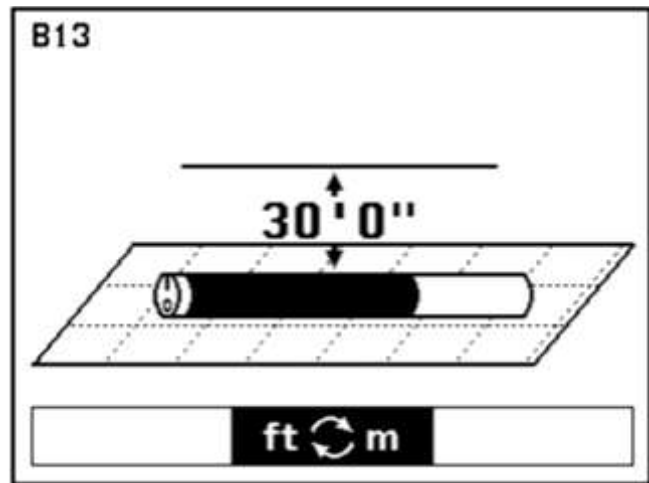
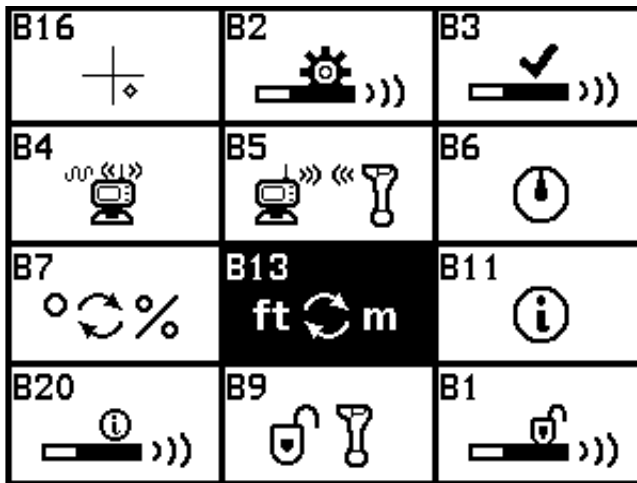

1. Press and hold to enter Setup Page.

2. Tap to select B13 icon.

3. Tap to enter Distance Unit Selection Page.

4. Tap or select unit and format.

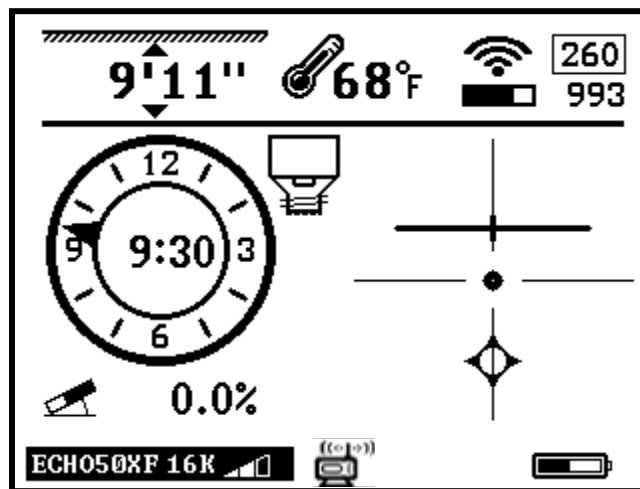

5. Tap to return to Main Page.

7.5.9: Time Setting (For dealer or factory user)

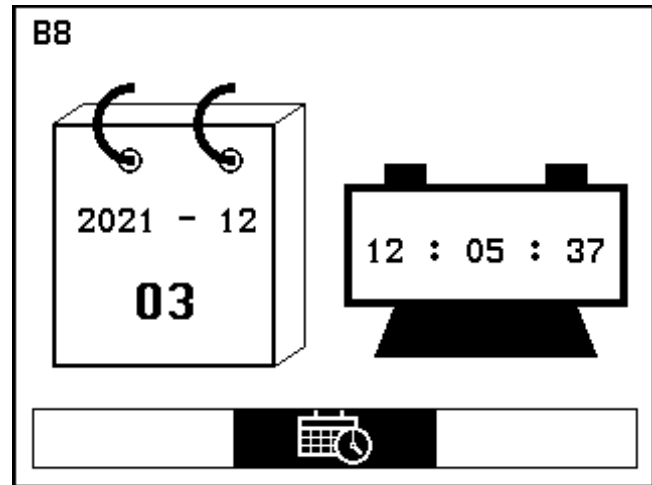
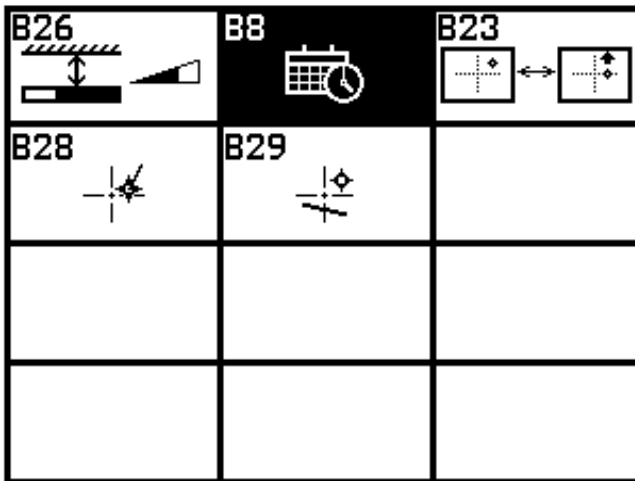

1. Press and hold to enter Setup Page.
2. Tap to select B8 icon.
3. Tap to enter Time Settings Page.
4. Tap select year, month, day, hour, or minute.
5. Tap or to set time.

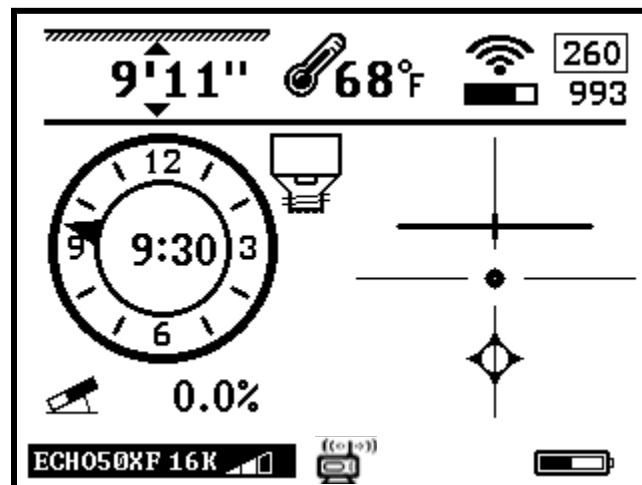

6. Tap to return to Main Page.

7.5.10: Manual System Lock/Unlock

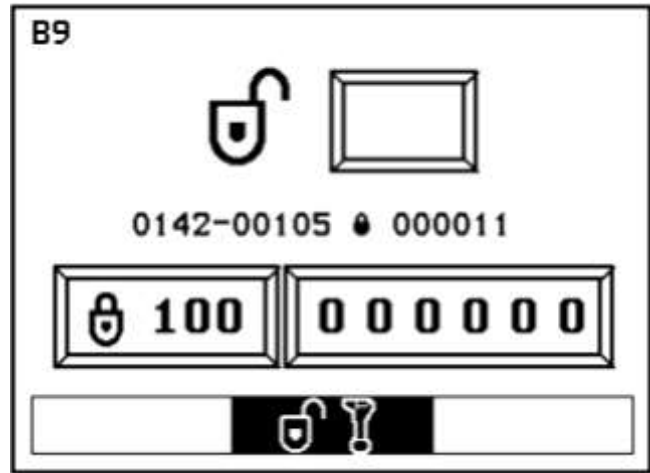
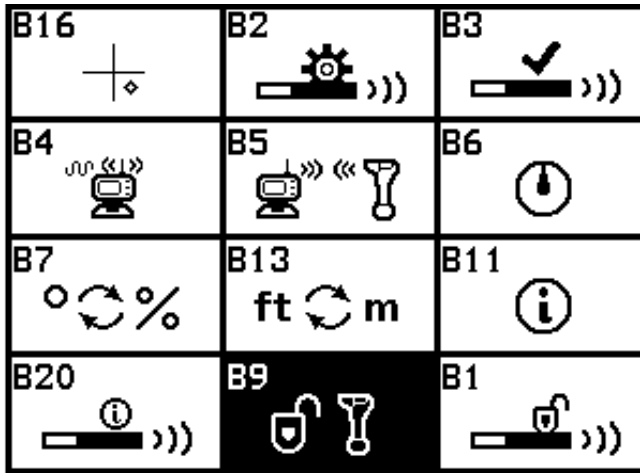

1. Press and hold to enter Setup Page. Tap to select B9 icon.
2. Tap to enter System Unlock Page.
3. Tap or and to input password.

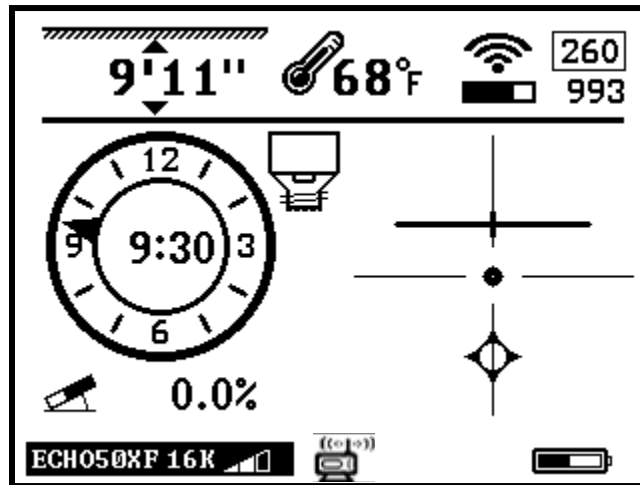

4. Tap to return Main Page.

7.5.11: Target Speed Control

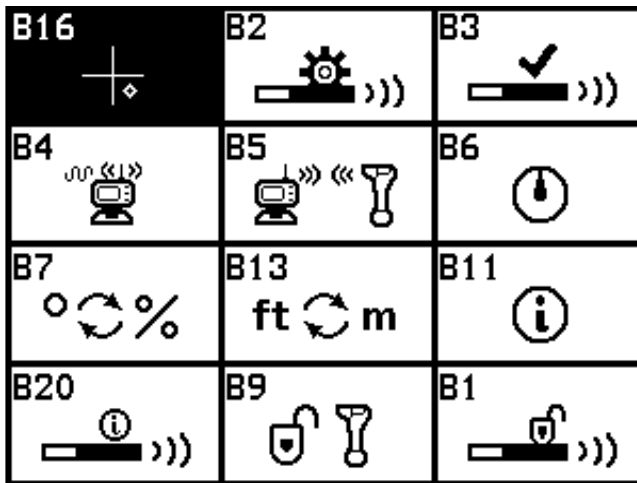

1. Press and hold to enter Setup Page.
2. Tap to enter the Speed Control Page.

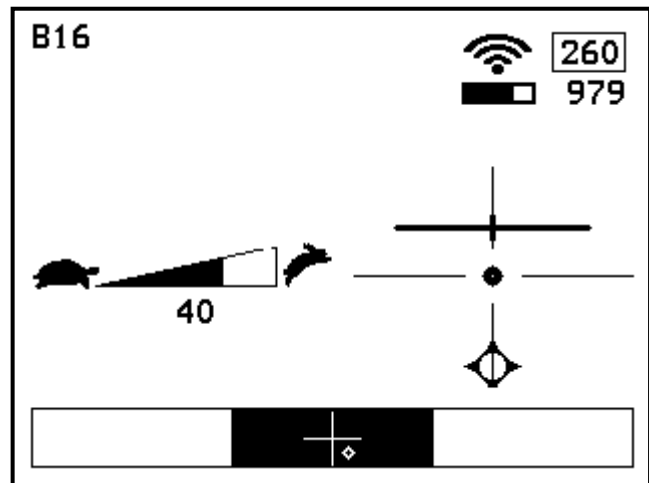

3. Tap and and to adjust speed.

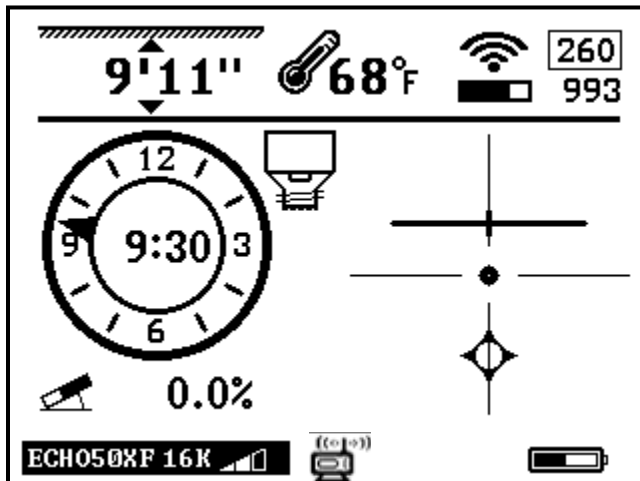





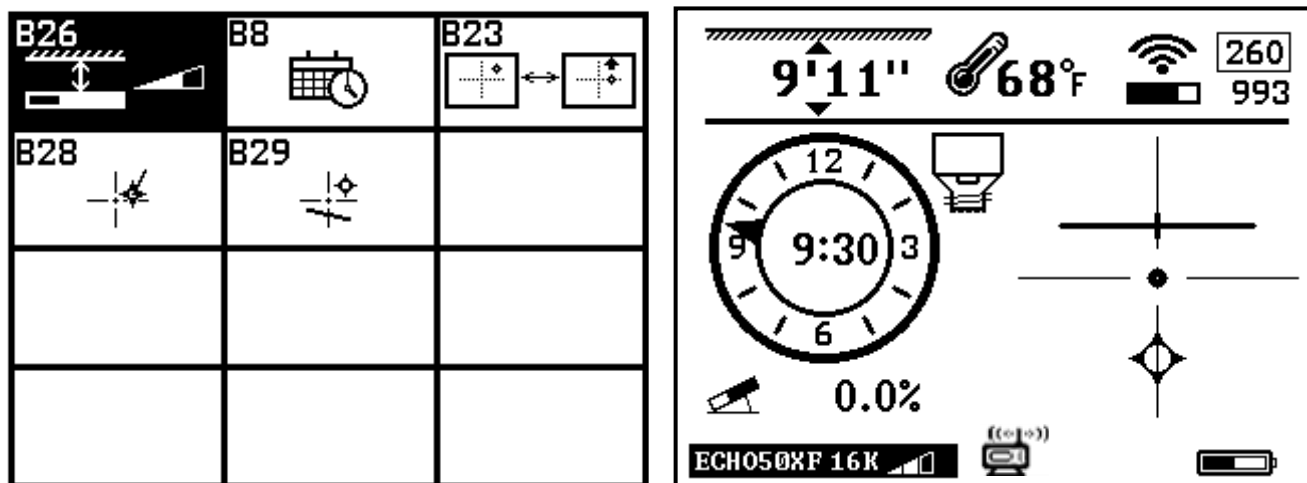

4. Tap to return Main Page.

NOTE:

Adjusting the speed control enables operators to more easily fine tune the left-right target and bore indicator when drilling at extreme depths.

7.5.12: Depth Speed Adjustment



1. Press and hold  to enter Setup Page.
2. Tap  until you move to the second Setup Page and select B26.
3. Tap  to enter Depth Speed Adjustment Page.
4. Tap  or  to adjust speed of depth displayed.
5. Tap  to return to the Main Page.

NOTE:

Adjusting Depth Speed allows the operator to control the depth readout when at extreme depths or high interference areas.

In these situations, depth readout can become erratic or bounce up and down making it difficult to pinpoint depth.

Slowing the speed of the depth readout will improve accuracy.

When over the top of the transmitter, adjust the speed until the desired speed is displayed.

7.6 Receiver Maintenance

- The receiver uses rechargeable lithium batteries. The receiver will automatically shut off if no key is pressed for over a period of 20 minutes or if there is no information received from the transmitter. It is strongly recommended that the batteries are taken out of the receiver if it is not being used for a long period of time to avoid potential corrosion.
- The receiver is an electronic measurement device. Severe shock and impact can damage the housing and the electronics inside the housing.
- Keep the receiver away from excessive heat to avoid damages to the plastic housing and the electronics inside the housing.
- Do not soak the receiver in excessive amounts of water.



8: Display



8.1 Display Specifications







Display	7-inch Color Touch Screen Android Operating System
Data-Log	Built-in
Temperature range	-4° to 140°F (-20°C to 60°C)
Radio Frequency	915 MHz
Telemetry	4 radio channels with range Up to 3,000 ft. (900m)*
Power	Rechargeable Lithium battery 12.5V
Battery Life	Up to 50 hours
Dimensions	7.5" x 5.1" x 7.5" (19cm x 13.9cm x 19cm)
Weight	3.3 lbs (1.5 kg)
Water resistant	IP65

7.2: Display Operation

-  Power key * Press and hold to turn on or off

-  Up key * Move to previous cursor selection.
* Tap to enter Data page for Bore-Log 

-  Down key * Move to next cursor selection
* Tap to view Bore Profile 

-  Confirm key * Tap to confirm cursor selection
* Tap on main page to record Bore data 

-  Setup key * Tap to return to main page.
* Press and hold to enter Configuration page

Page 43







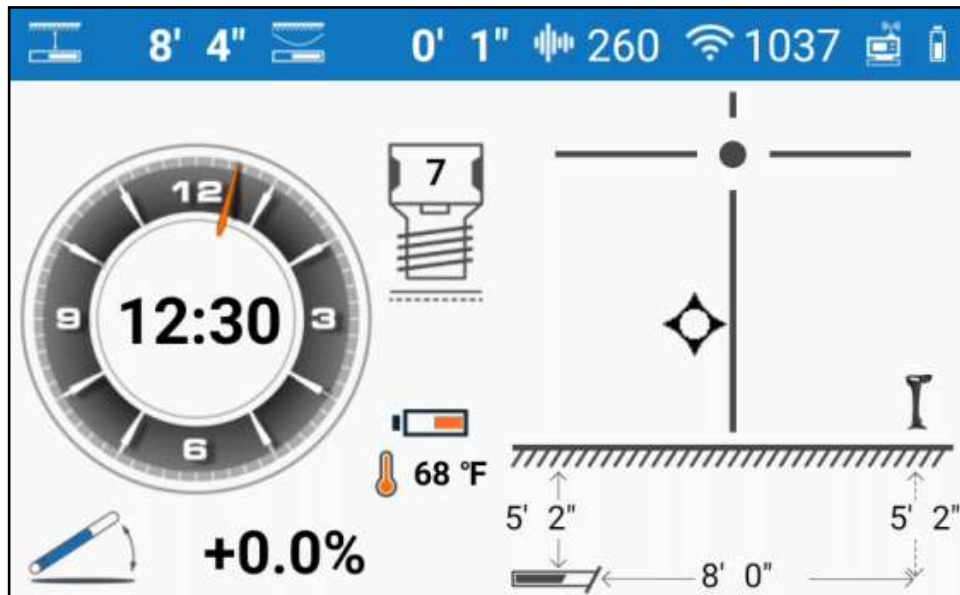

* With optional Yagi Antenna

8.3 Display Icons

8.3.1 Main Page Icons



Bore-To Mode

-  **8' 4"** • Depth or Distance between transmitter and receiver
-  **0' 1"** • Relative Depth calculated with average pitch
-  **260** • Signal to noise ratio number
-  **1037** • Transmitter signal strength
-  • Receiver remote telemetry indicator and Display Battery life
-  • Rod Counter
-  **68 °F** • Transmitter temperature and battery life
-  **+0.0%** • Transmitter Pitch

8.3.2 Setup Page Icons

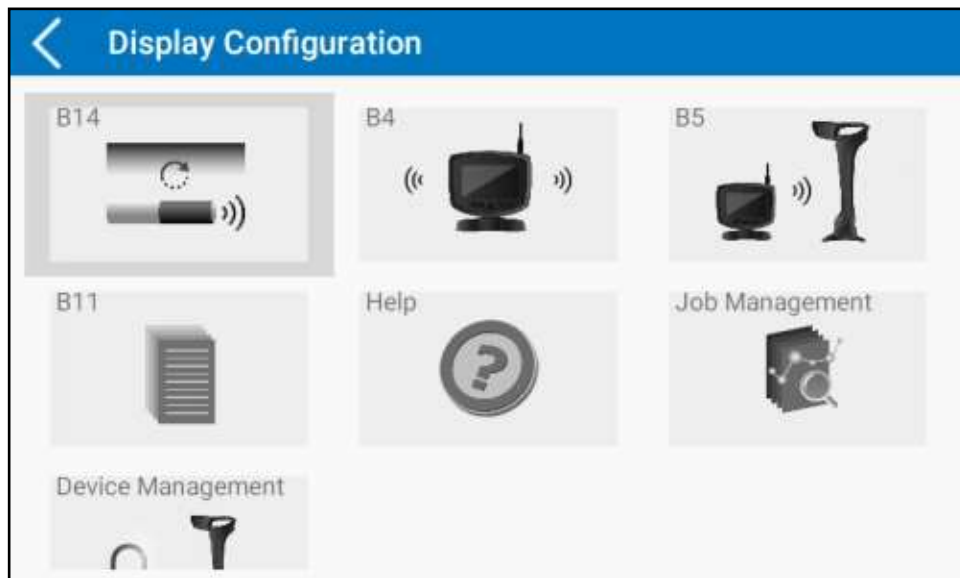

B14: Down hole Echo frequency change

[Page 39](#)

B4: Radio Channel Selection

[Page 41](#)

B5: Receiver and Display pairing

[Page 42](#)

B11: System Info

* Settings

[Page 52](#)

* Job Management

[Page 44](#)

* Device Management

[Page 49](#)

* Help

[Page 53](#)

8.4 Down Hole Echo Frequency Change - B14

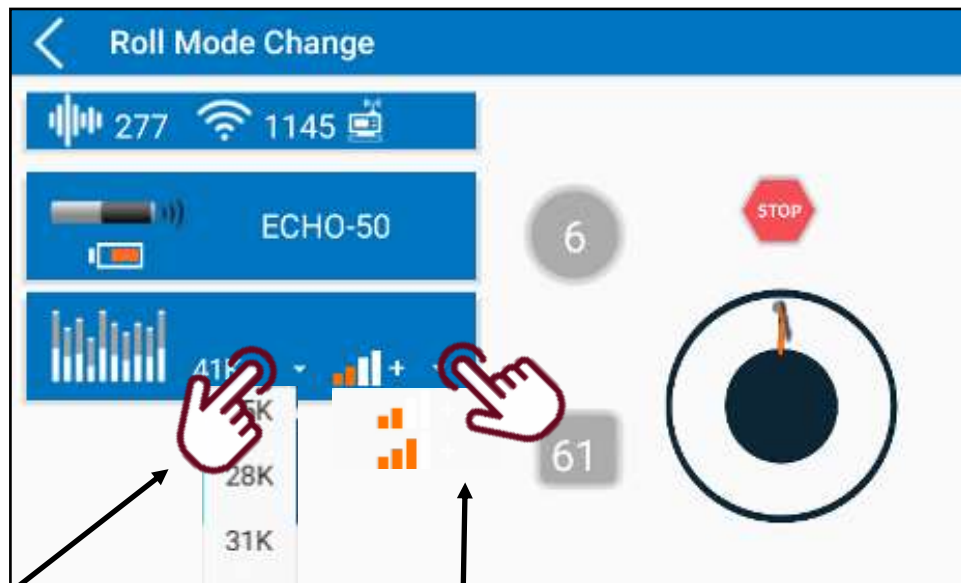

Tap here to select
new frequency

Tap here to select
power mode



Roll Indicator - Press to
begin Frequency Change



Steps remaining



Target Dot



Roll Instructions



Hold: hold this roll position
until it counts down to 0



Proceed to next roll position

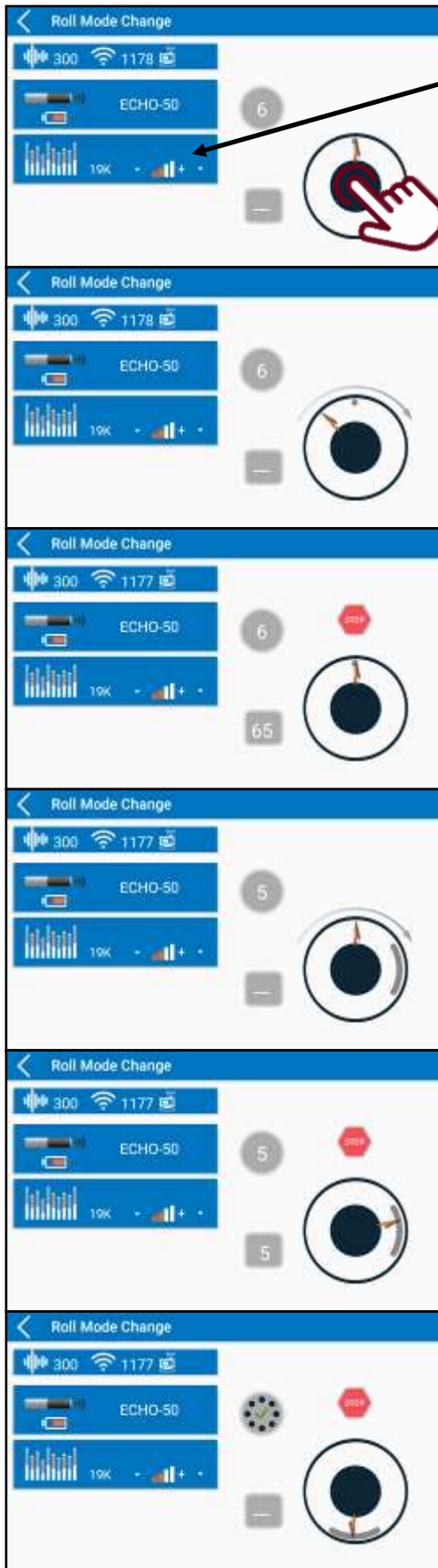

First, choose the desired frequency the transmitter needs to be switched to. Then, choose the power level.

Tap the center of the roll indicator to begin.

Rotate drill head clockwise until the roll indicator points toward target dot.

Instructions will change from the clockwise arrow to "STOP"

Rotate drill head to next position in sequence before the counter reaches 0 or the sequence will be cancelled.

If the next step has the target dots in the same place as the previous step, rotate the drill head one entire rotation until the roll indicator lines up with the target dots again.

Once all six steps of the sequence are complete a check mark will appear.

Next, change the Transmitter Settings on the receiver (B3) to match the new frequency and power levels.

B16	B2	B3
B4	B5	B6
B7	B13	B11
	ft m	
B20	B9	B1



8.5: Telemetry Channel Selection - B4

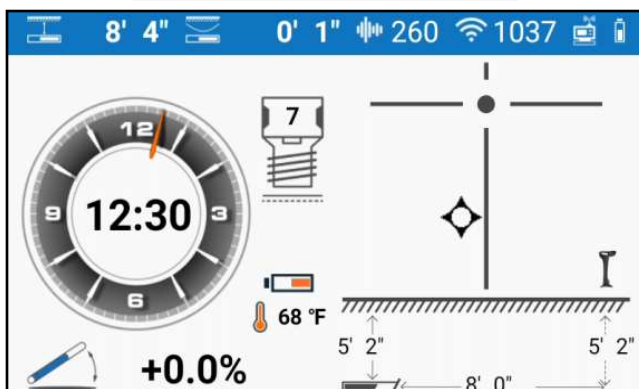
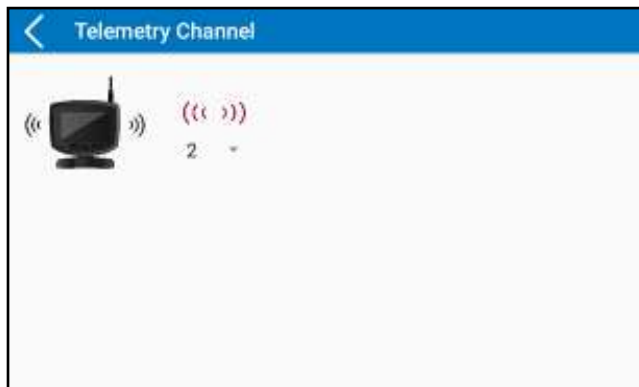
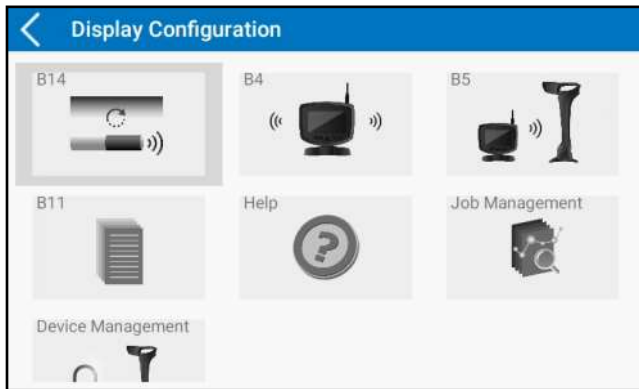

1. Press and hold  to enter Display Configuration Page.

2. Tap  to select B4 icon.

3. Tap  to enter Telemetry Channel Selection. Or tap B4 with your finger.

4. From this page, 4 different radio telemetry channels are available to choose from.

5. Tap the drop down arrow to select from 4 different radio telemetry channels.

The Receiver and Display must be on the same Channel in order to communicate.

6. Tap  twice to return to Main Page

8.6: Receiver & Display Pairing - B5

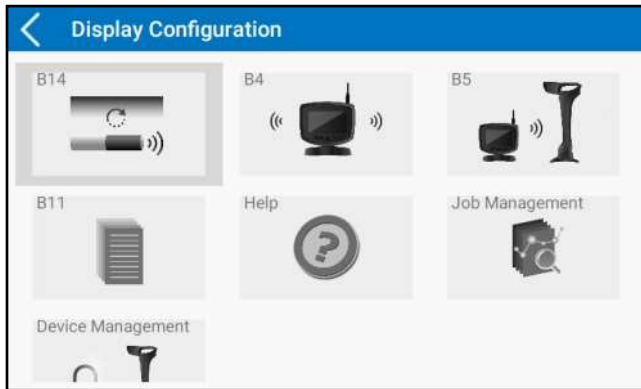

1. Press and hold  to enter Display Configuration Page.

2. Tap  to select B5 icon.

3. Tap  to enter Pairing Page.

Alternatively, use your finger to tap B5.



4. Tap the icons to start pairing. It is required that the following procedure be performed on the receiver (B5) at the same time.



5. Pairing is complete.

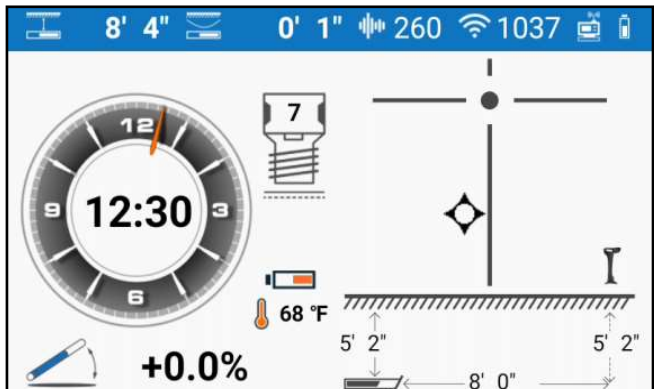

6. Tap  twice to return to Main Page.

8.7: Brightness Adjustment

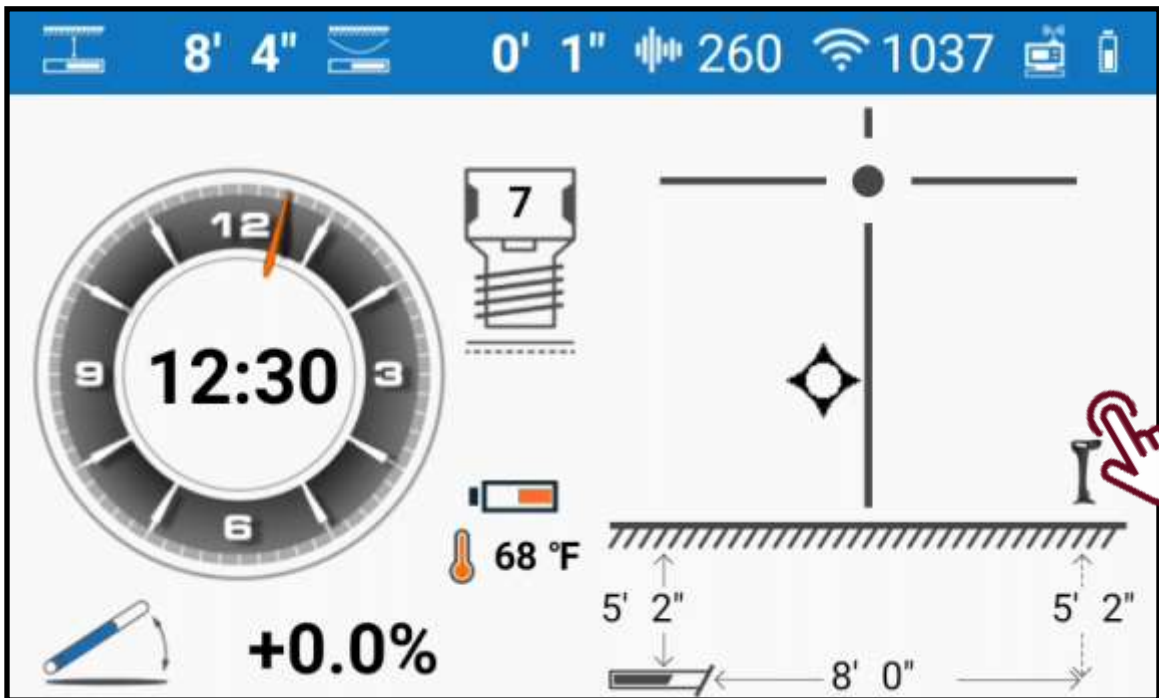

From the Main Display Page, with your finger tap on the right side of the screen as shown above. A slider will appear. Hold your finger on the blue indicator to adjust the brightness level of the display.

8.8: Bore Log

8.8.1: Job Management

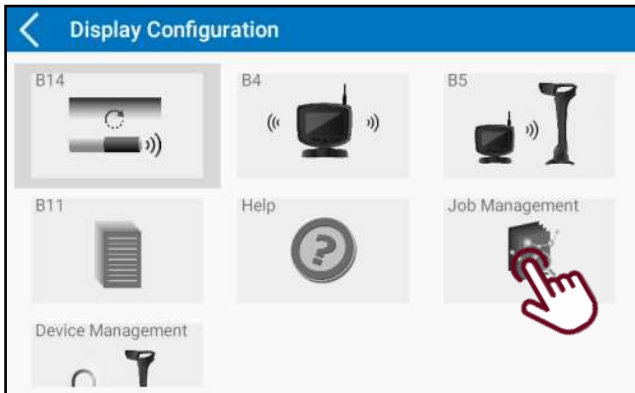

1. Press and hold  to enter Display Configuration Page.

2. Tap  to select Job Management.

4. Tap  or use your finger to enter Job Management.



3. From this page you may view your current job information or tap  the to create a new job.

8.8.2: Creating a New Job profile

From this page the information pertaining to the new job may be manually entered.

← Project Name

← Project Location

← First Rod Length

← Default Rod Length

- See next page

Additional Details:

The remaining details can be set and edited later if needed.

8.8: Bore Log

8.8.3: Setting the Rod Lengths



When creating a new job profile, the rod lengths must be accurately entered in order to achieve data accuracy

First Rod Length:

- * Proceed with drilling until the housing is halfway into the ground. This will be your starting point.
- * Measure the length of the rod from the drive chuck to the breakout wrenches on the drill rig. This measurement will be your “First Rod Length”. In this example our first rod length is 4’6”.

Default Rod Length:

- * This is the full measurement of the drill pipe being used on the drill rig.
- * Most drill rigs use a standard 10’ pipe like the example above.

8.8: Bore Log



8.8.4: Data Logging

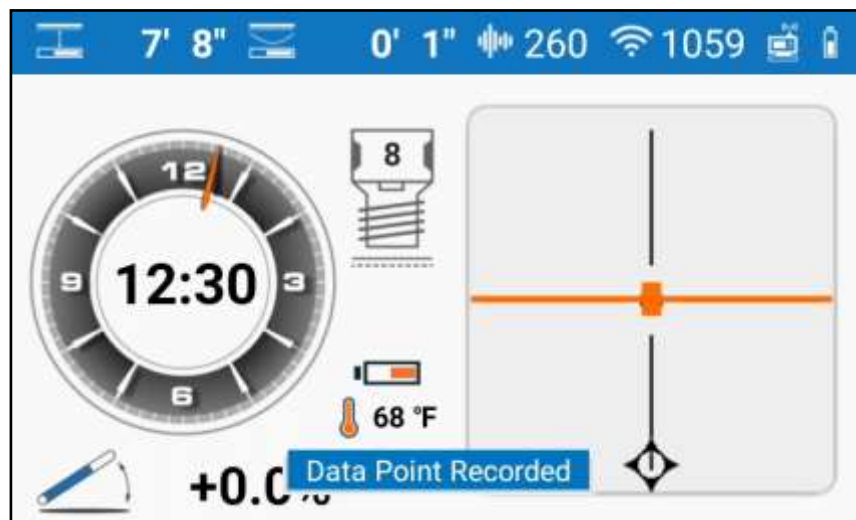

After setting your Job Profile Info, return to the main locating screen. With your drill head half way in the ground as mentioned on the previous page, tap  to record your starting data point. Your screen should look like the screen below:



The first data point indicated by the 0 in the Rod Counter  records the pitch of your first rod and will be your starting data point for the bore profile.

Continue to drill your first rod completely down and tap  on the Display to record your first rod / data point. Continue to load your next rod. Your rod counter should show a 1  and will be flashing.

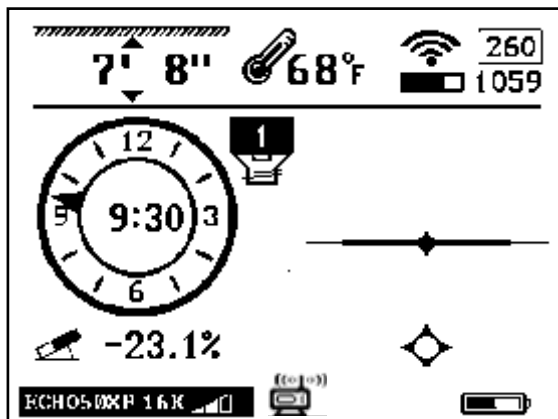

Once the drill operator records the first rod / data point, the Receiver will show Rod 1 in the rod counter as shown here. The rod counter will be flashing.

From here locate the drill head then proceed to press the  button on the Receiver to record the data. Repeat this process for each rod.

8.8: Bore Log

8.8.5: Bore Profile



At any time during the bore, the drill operator may check the Bore Profile by pressing the  key. In the below example, 18 Total Rods or data points have been recorded. We can see the total distance of the bore is 172'4" and the Max Relative Depth is 14'9". Below that is the information gathered from the latest rod / data point.

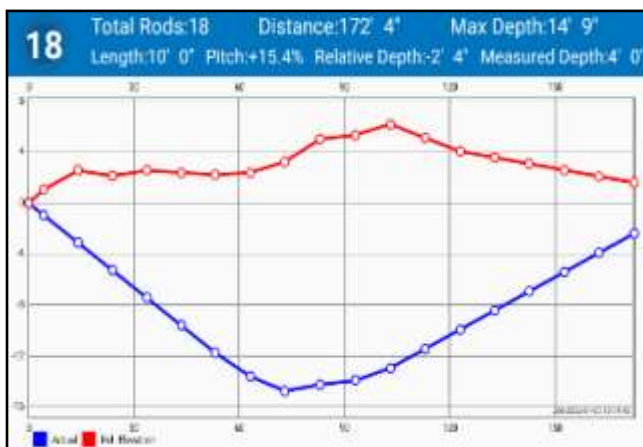

The **RED** line represents the above ground elevation as it changes along the bore path. The **BLUE** line represents the Relative Depth of the drill head along the bore path. The distance between each corresponding **RED** and **BLUE** point on the graph is the Measured Depth of each rod / data point.

8.8.6: Data Point Information Screen

Rod#	Pitch	Depth	Relative Depth	Depth Change	
18	+15.4%	4' 0"	-2' 4"	1' 6"	     
17	+15.4%	6' 0"	-3'10"	1' 6"	   

If at any point the information for a data point needs to be edited, the data point information screen can be accessed by pressing the  key from the main locating screen.

This screen will show the data for each rod starting with the most recent rod at the top.

Tap  to edit individual data points.

Tap  to manually add a data point.

Tap  to delete the most recent data point.

8.8: Bore Log

8.8.7: Generating Reports



From the Job Management screen, select the specific job you would like to view a report on.

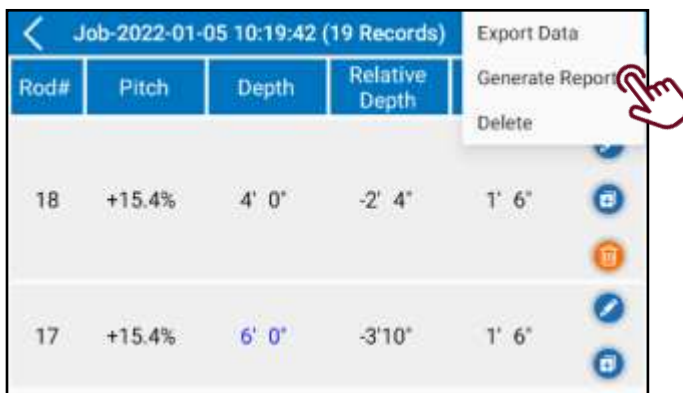

Using your finger tap the  at the top right of the screen and select Generate Report. You may also delete the selected job if needed.

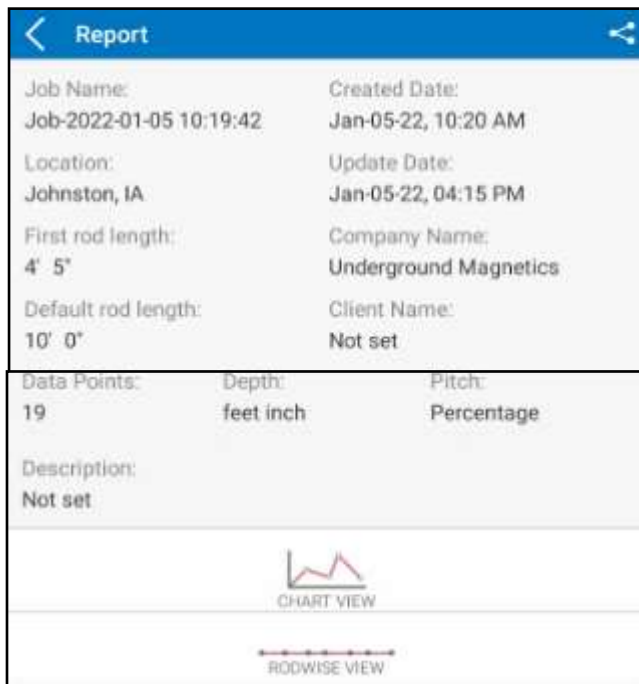

From here you may view specific information about the selected job and email reports* by selecting the  symbol at the top right hand corner of the screen as shown here.

*Device is equipped with a SIM card. If cell service is unavailable, Wi-Fi or Hotspot service is required.

8.9: Device Management

Automatically unlock your Receiver and Transmitters from the Display. **Note:** The Receiver and Transmitter must be on and within Bluetooth range to unlock.

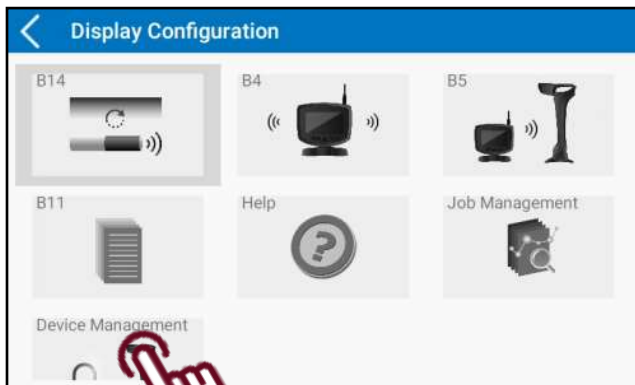

From the Display Configuration page, select Device Management.



On this page we see the available connected devices. In the above example the connected Transmitter and Receiver and their respective Serial Numbers are shown. To unlock a device select the device to proceed to the next screen.

8.9.1: Automatic Receiver Unlock

In case of a financed or loaner locator unit, the Receiver may be locked for a specified number of days. The unlock period is managed by Underground Magnetics and set based on the financed agreement.

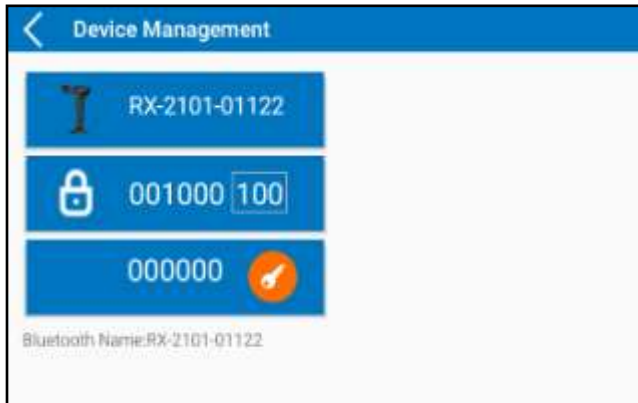

This screen displays the serial number for the Receiver at the top, followed by a unique 6 digit unlock code with the number of days remaining on the lock.

To unlock or reset the lock on the device, tap the  button and the system will automatically update as shown below indicated by the open padlock symbols on both the Receiver and Display.

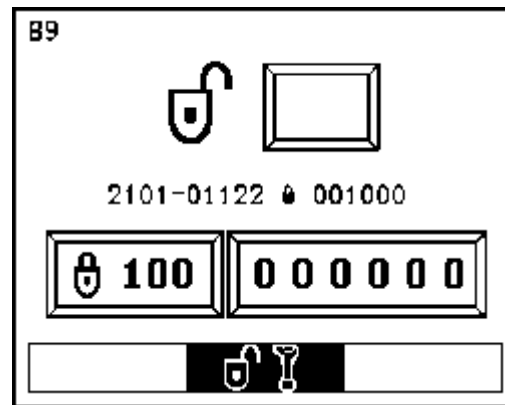
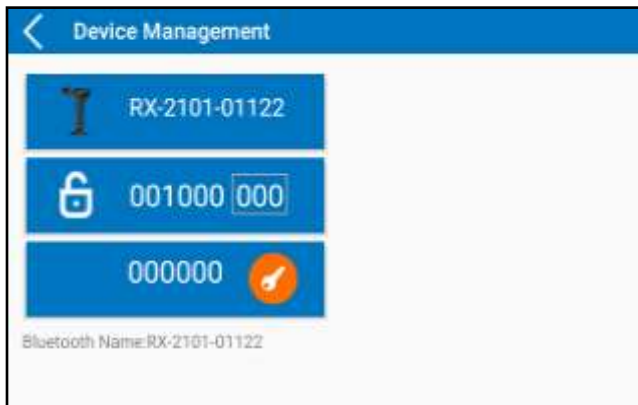

For technical assistance, call Underground Magnetics at (515)-505-0960.

8.9.2: Automatic Transmitter Unlock

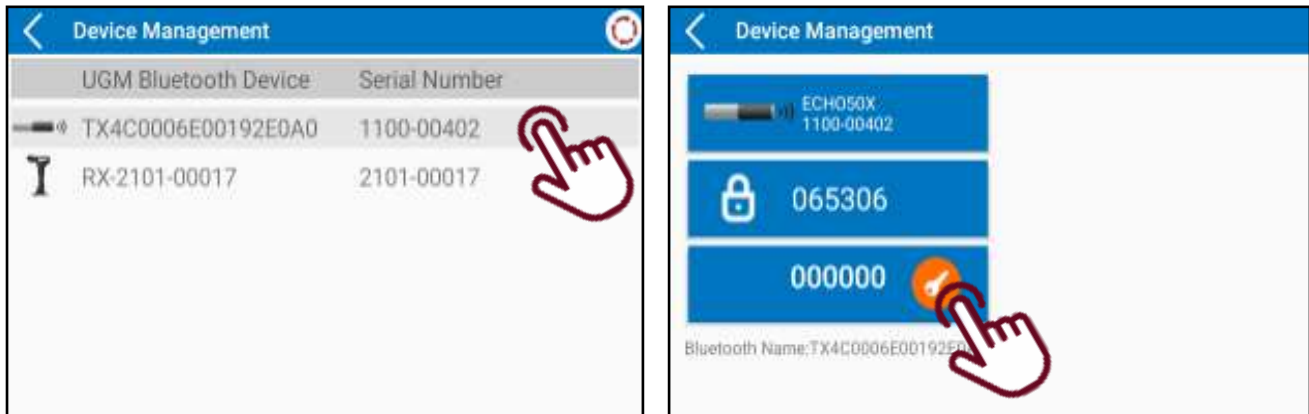

When unlocking a transmitter, a battery must be placed inside the transmitter and paired to the locator. Follow the same process as listed on the previous page and select the  button.

Please note, unlocking a transmitter will prompt the below warning. This indicates that once the transmitter is unlocked, the 1-year warranty will start from the day of unlock.

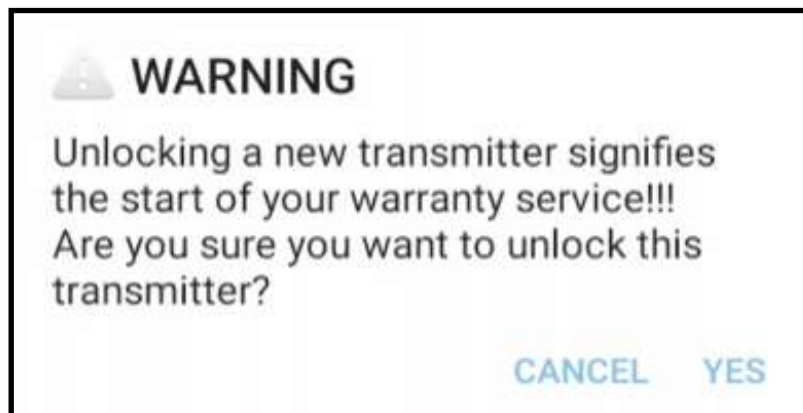

For technical assistance, call Underground Magnetics at (515)-505-0960.

8.11: Help

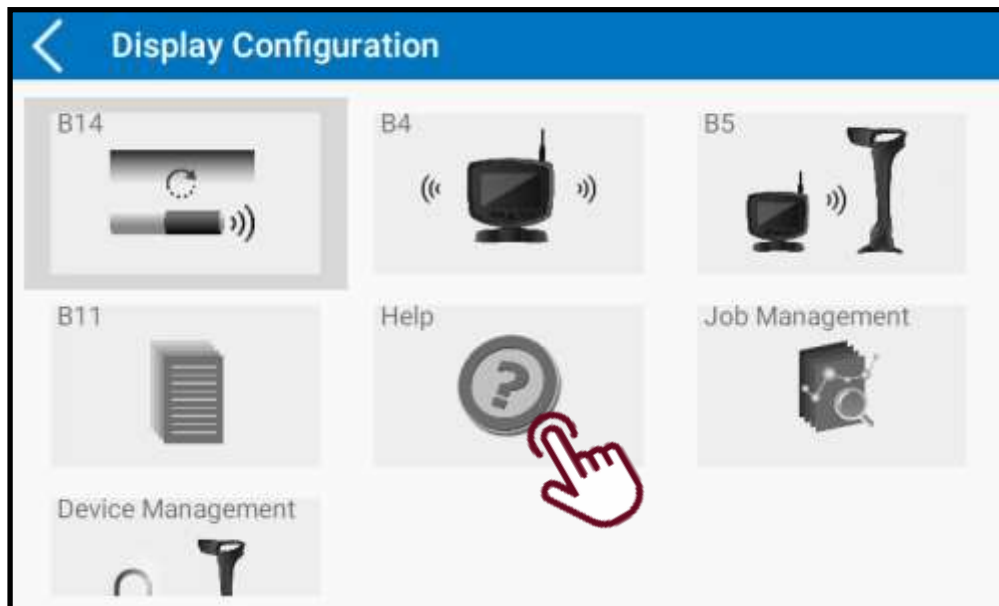

From the Display Configuration Page, scroll down and select the Help icon. From here you may view useful topics from this Manual.

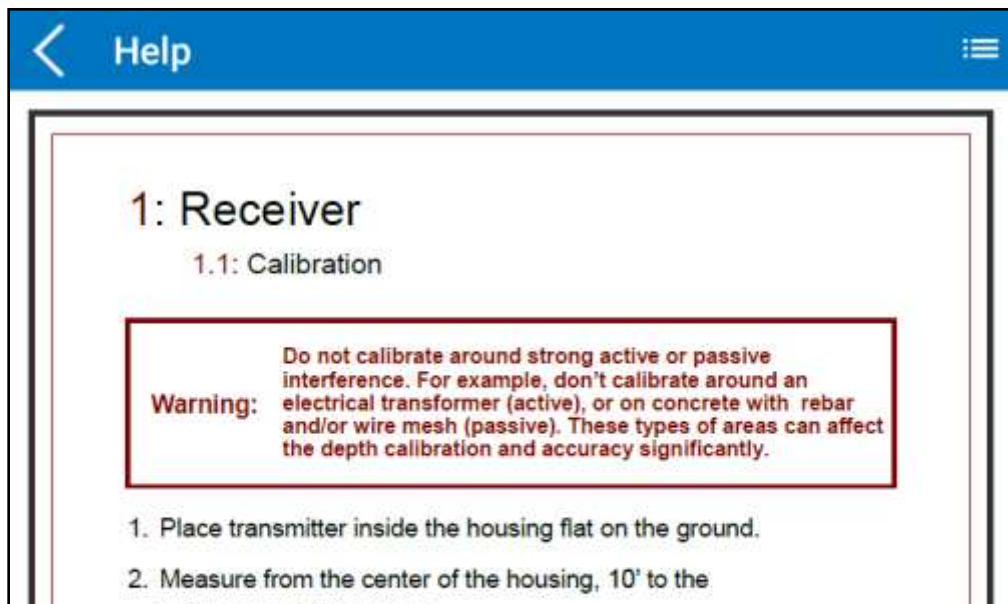

8.12: Display Maintenance

- The display uses rechargeable lithium batteries. The display will automatically shut off if no key is pressed for over a period of 20 minutes or if there is no information received from the receiver. It is strongly recommended that the batteries are taken out of the display if it is not being used for a long period of time to avoid potential corrosion.
- The display is an electronic measurement device. Severe shock and impact can damage the housing and the electronics inside the housing.
- Keep the display away from excessive heat to avoid damages to the plastic housing and electronics inside the housing.
- Do not submerge the display in excessive amounts of water.

9: Transmitter

9.1: Introduction

The transmitter provides drill head temperature, clock position pitch, battery status and locating signal. The transmitter transmits signals at .3kHz, .6kHz, 1kHz, 2kHz, 4kHz, 7kHz, 10kHz, 12kHz, 16kHz, 19kHz, 22kHz, 25kHz, 28kHz, 31kHz, 36kHz and 41kHz. The transmitter will enter a “sleep” mode after 15 minutes without rotation. It takes 10 seconds to “wake up” once the transmitter is rotated.

Note: If drilling in adverse soil conditions (i.e. rock), normal C cell batteries will experience battery chatter. This can greatly reduce battery life. To prevent this, use your provided double C lithium or UM Rechargeable Echo Cell Kit.



9.2: Specifications

Echo XMINI



Dimensions	1" X 8" (2.5 cm x 20.3 cm)
Frequency	2 frequencies 19kHz and 30kHz
Depth Range	60ft (18m)
Power	(1) 18650 rechargeable lithium battery
18650 (3.7V)	18 hours
Temperature	Under 190° F (87° C)
Battery Voltage	2.7V—4.2V

Echo ST

Dimensions	.78" X 6.3" (1.98 cm x 16 cm)
Frequency	31kHz
Depth Range	60ft (18m) - Normal Mode
Power	(1) 16340 rechargeable lithium battery
18650 (3.7V)	18 hours
Temperature	Under 190° F (87° C)
Battery Voltage	2.7V—4.2V



9.2: Specifications

Echo 50



Dimensions	1.25" X 15" (3.2 cm x 38 cm)
Frequency	12 frequencies 4kHz-41kHz
Depth Range	90ft / 130ft / 130ft (27.4m / 40m / 40m)
Power	Echo Cell Kit (21700) or Lithium Battery (261020)
21700 (4.2v)	Normal Power: 50 hours High Power: 12 hours
261020 (3.7v)	Normal Power: 60 hours High Power: 15 hours
Temperature	Under 220° F (104° C)

Echo 50XF

Dimensions	1.25" X 15" (3.2 cm x 38 cm)
Frequency	16 frequencies .32kHz-41kHz
Depth Range	Normal Power: 131ft (40m) High Power: 164ft (50m)
Power	Echo Cell Kit (21700) or Lithium Battery (261020)
21700 (4.2v)	Normal Power: 50 hours High Power: 12 hours
261020 (3.7v)	Normal Power: 60 hours High Power: 15 hours
Temperature	Under 220° F (104° C)



9.2: Specifications



Echo 75XF

Dimensions	1.25" X 19" (3.2 cm x 48 cm)
Frequency	16 frequencies .325kHz-41kHz
Depth Range	Low Power: 114ft (35m) Medium Power: 180ft (55m) High Power: 278ft (85m)
Power	(2) 26650 rechargeable lithium
26650 x 2	Low Power: 100 hours Medium Power: 60 hours High Power: 11 hours
Temperature	Under 190° F (121° C)
Battery Voltage	5.6V—8.4V

Echo 70

Dimensions	1.42" X 15.94" (3.6 cm x 40.5 cm)
Frequency	12 frequencies 4kHz-41kHz
Depth Range	Normal Power: 164ft (50m) High Power: 230ft (70m)
Power	(3) 18650 rechargeable lithium batteries
18650 (3.7V)	Normal Power: 60 hours High Power: 15 hours
Temperature	Under 250° F (121° C)
Battery Voltage	8.4V—12.6V



9.2: Specifications



Echo 90

Dimensions	1.42" X 18" (3.6 cm x 45.7 cm)
Frequency	12 frequencies 4kHz-41kHz
Depth Range	Normal Power: 230ft (70m) High Power: 295ft (90m)
Power	18650B2 rechargeable lithium batteries
18650B2 (3.7V)	Normal Power: 80 hours High Power: 20 hours
Temperature	Under 250° F (121° C)
Battery Voltage	5.6V—8.4V

Echo 110

Dimensions	1.42" X 24" (3.6 cm x 60.9 cm)
Frequency	12 frequencies 4kHz-41kHz
Depth Range	Normal Power: 295ft (90m) High Power: 360ft (110m)
Power	(3) 18650B2 rechargeable lithium batteries
18650B2 (3.7V)	Normal Power: 120 hours High Power: 30 hours
Temperature	Under 250° F (121° C)
Battery Voltage	8.4V—12.6V



9.3: Digital Information

- **Pitch:** From -100% to +100% with 0.1% resolution within the range of –45% to +45% and 1.0% resolution outside of that range.
- **Roll:** 24 transmitter roll positions.
- **Battery:** Install batteries positive side down and install battery cap with provided battery cap tool.
 - • **Lithium:** Echo Power Cell will show full until completely dead.
 - **Echo Cell Kit:** Rechargeable Lithium Echo Cell Kit will meter battery life while discharging.

Note: See **7.5.4** to select battery style that will be used in transmitter.

- **Temperature:** When the transmitter is overheating, temperature indication in the receiver's display flashes. If temperature reaches over 190° transmitter may be permanently damaged.

9.4: Transmitter Maintenance

- Do not place the transmitter near excessive temperature over 190°F.
- Do not apply excessive pressure, shock or vibration on the transmitter.
- Take the battery out of the transmitter after use.
- Clean the spring and cap on the battery compartment when necessary.
- Regularly check the sealing ring on the battery cover. Replace if necessary.

10: Locating Methods

One major advantage of the Mag system is its simplicity. Once the receiver and the transmitter are paired, the operator is not required to push any buttons to pinpoint the location, direction or depth of the transmitter.

10.1: Three Point Locating

10.1.1: The Basics

The Mag receiver locates the transmitter by pinpointing three specific locations along the transmitter's magnetic field. The front null point (FNP) ahead of the transmitter, the rear null point (RNP) behind the transmitter and the locate line (LL) above the transmitter.

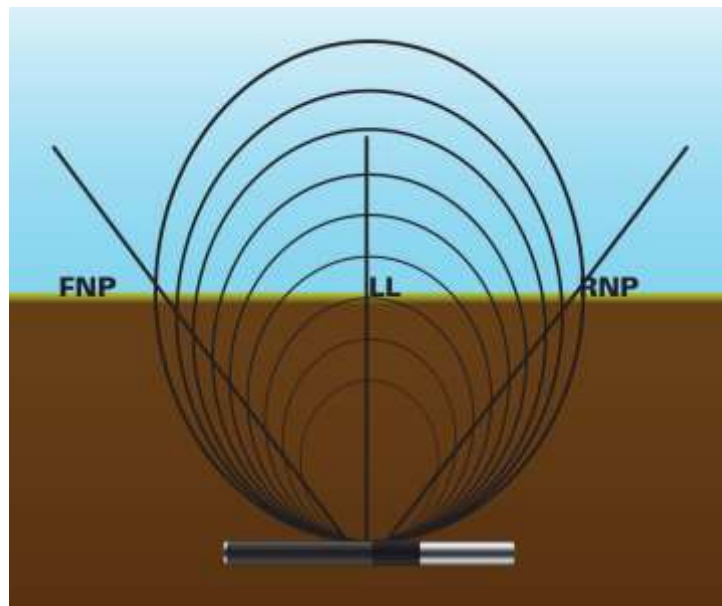

GUI Options– Single Point vs Single Target; Line Indicators

Our software enables the user to toggle options within the graphical user interface. The operator is able to choose between Single Point or Single Target as well as Directional and Locate lines to assist in locating the transmitter's Front and Rear Null Points as well as the Locate Line.

Single Point displays arrows leading you to the closest null point.

Single Target displays the location of the closest null point with a target only. Move in the direction of the target to pinpoint the location.

Toggle Single Point / Single Target

The screens below show the same location over the head, one in Single Point and the other in Single Target.

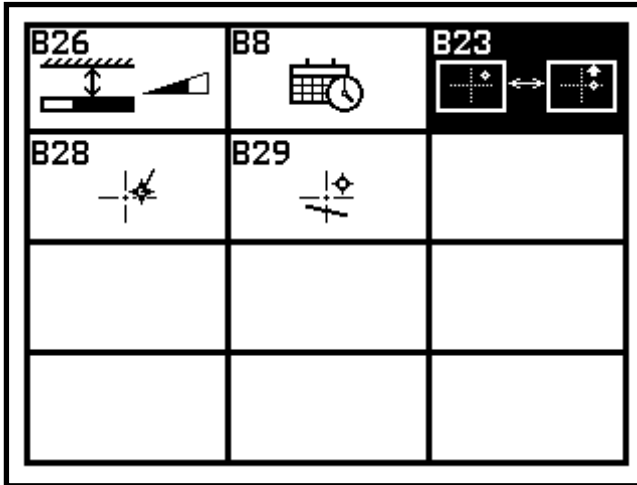

1. Press and hold to enter Setup Page.
2. Tap until you switch to the Second Setup Page and select B23.
3. Tap to enter Single Point, Single Target Selection Page.
4. Tap to choose either Single Point or Single Target locating modes.

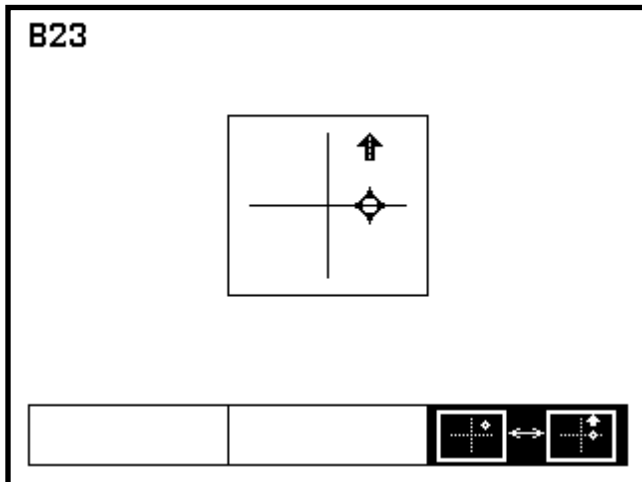



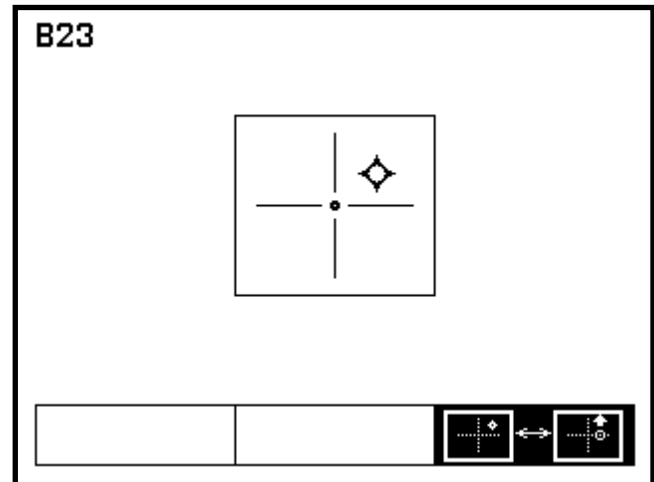

Single Point Locating Mode

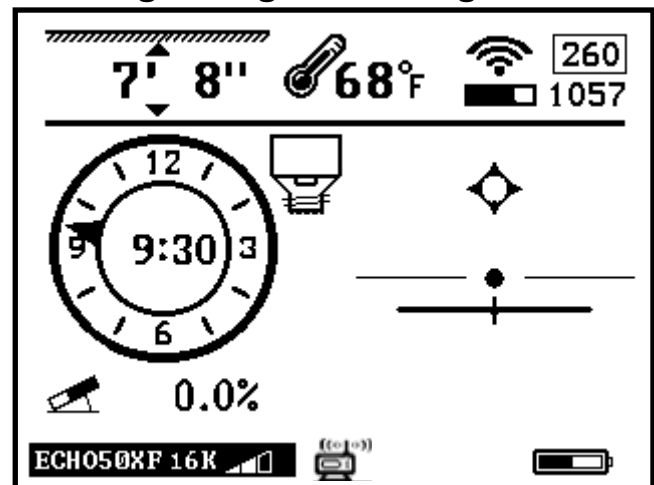
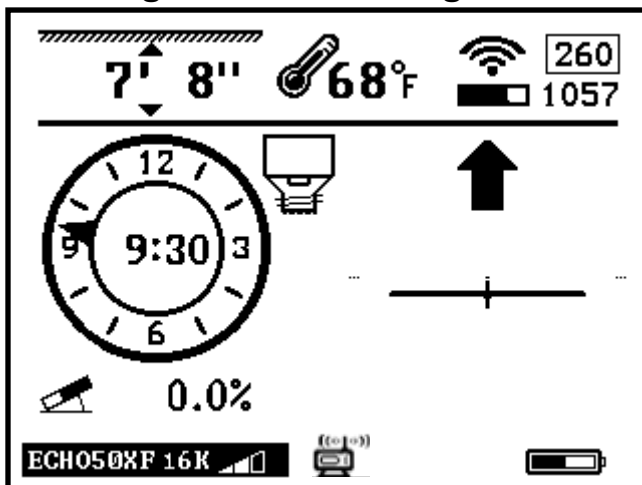





Single Target Locating Mode



Toggle Directional and Locate Line On/Off

1. Press and hold  to enter Setup Page.
2. Tap  until you switch to the Second Setup Page and select B28.
3. Tap  or  to turn Directional Line on/off.
4. Tap  to return to Main Page.

1. Press and hold  to enter Setup Page.
2. Tap  until you switch to the Second Setup Page and select B29.
3. Tap  or  to turn Locate Line on/off.
4. Tap  to return to Main Page.

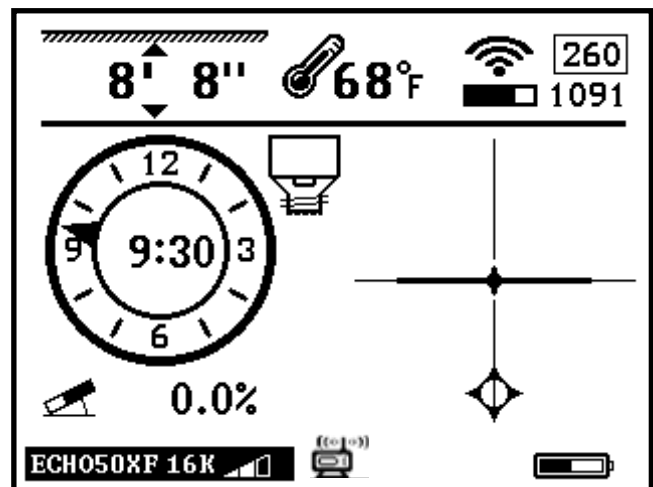
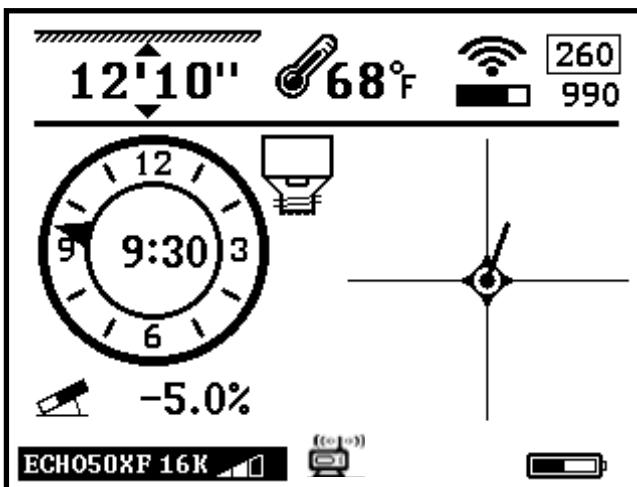
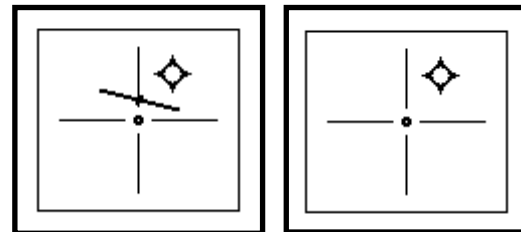
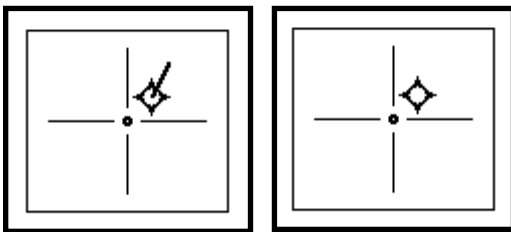
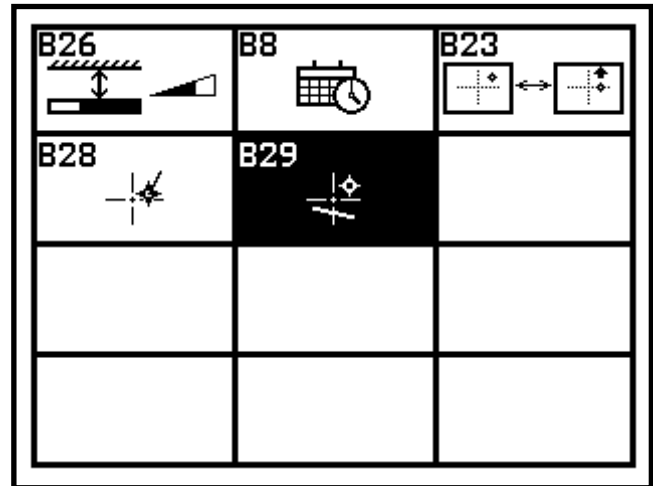
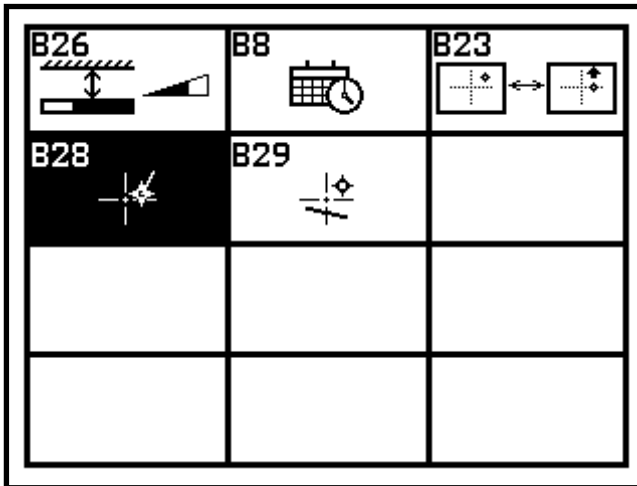

10.1.2: Find the Transmitter

The Locate Line (LL) extends left and right of the transmitters center. Because of the physics of the locators magnetic field, the LL can look the same several feet to the right or left of the transmitters actual location. This is why it is important to at least locate the front null point (FNP) first before moving back to locate the head. For pinpoint location, find both the FNP and RNP before moving over the head. Draw a string line between the FNP and the RNP and your head will be directly in line and in between these points.

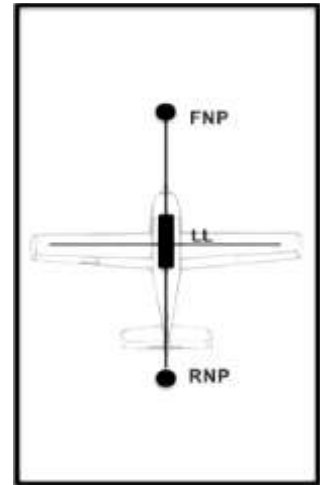

Think of the transmitter as the shape of an airplane. The FNP is the nose and the RNP the tail. Find the FNP and the RNP and the center of the transmitter is centered over the wings.

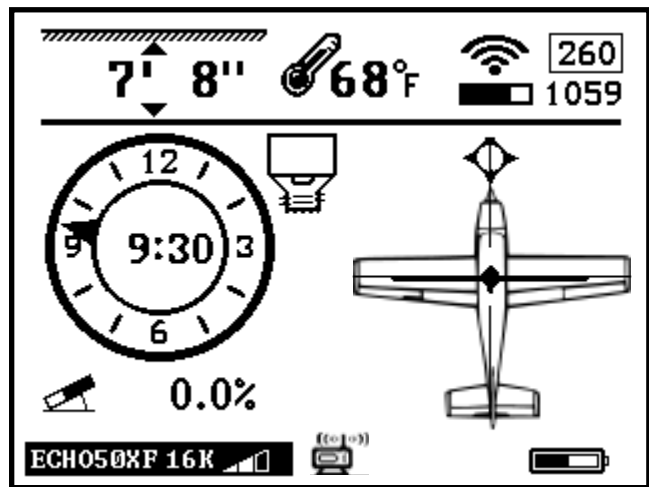
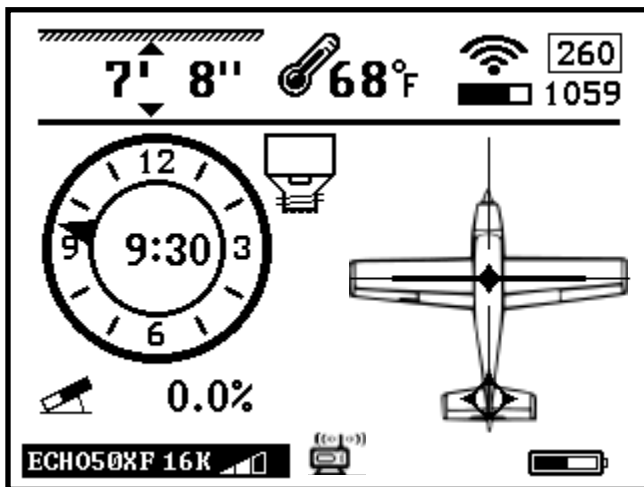
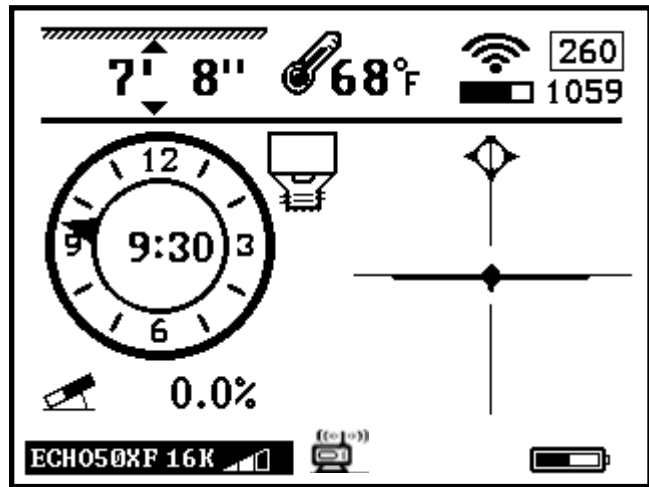
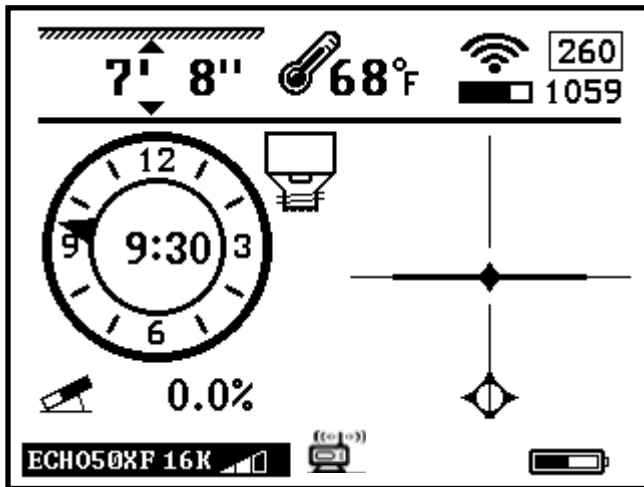

10.1.2: Finding the Front Null Point

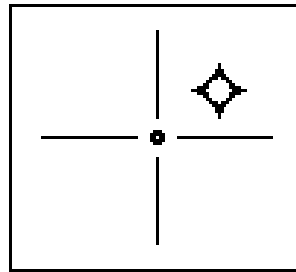
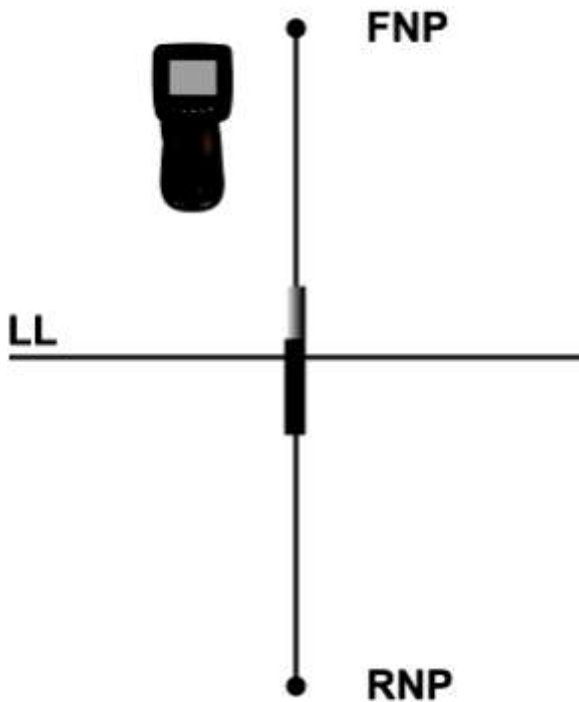

Single Point

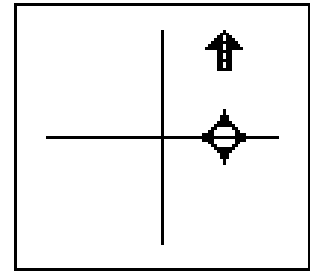

Single Target

In this scenario the transmitter is behind you and you are walking toward the Front Null Point (FNP.)

To locate the FNP in this scenario, move forward and to your right until the Target centers on the crosshair. You are now at the FNP.

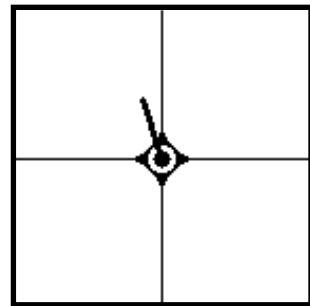
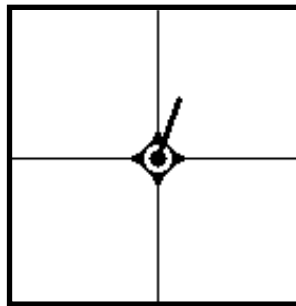
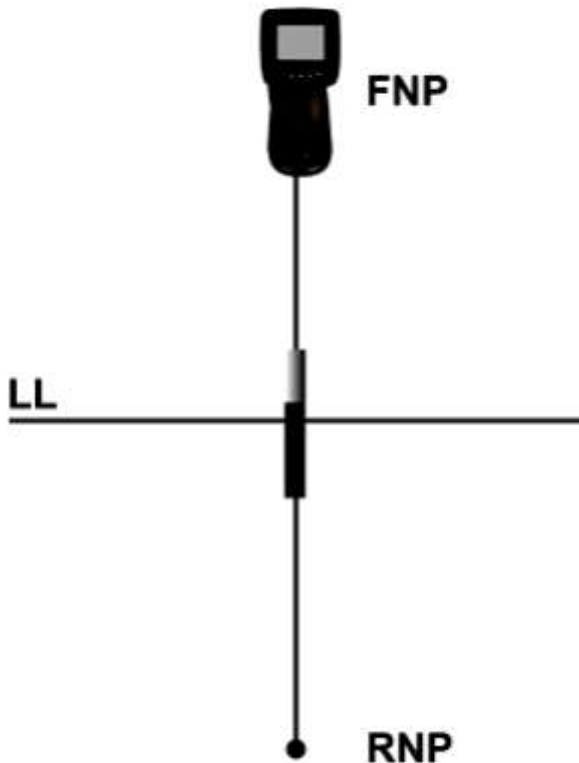

At the FNP, rotate the locator in hand left or right until the Directional Line is centered, indicating the transmitter is directly in line behind you.

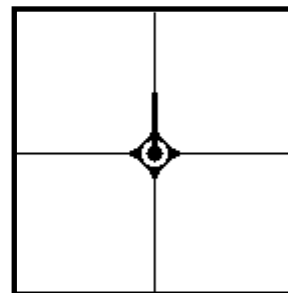

10.1.2: Locating FNP, RNP and LL

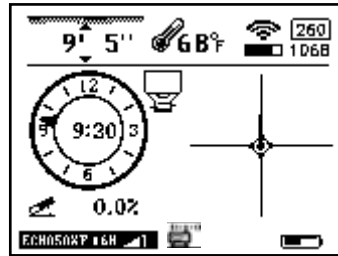
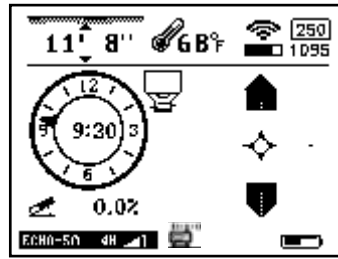
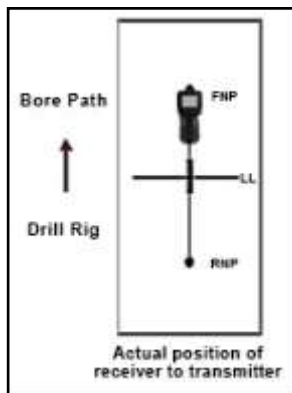

Front Null Point (FNP)

The FNP is a point in front of the transmitter. (Think of it as the sight at the end of a rifle.) This is the direction of the transmitter.

Locate it by putting the **Target** in the center.

In Single Point, move in the direction of the arrow until the target appears.

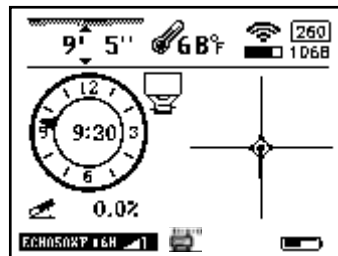
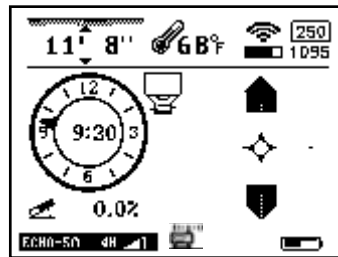
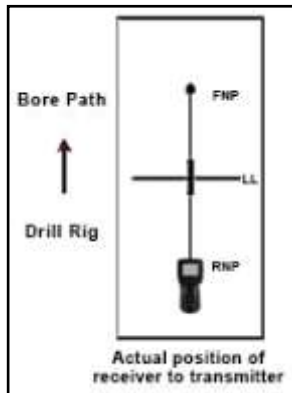

Rear Null Point (RNP)

Next, find the RNP. The RNP is a point behind the transmitter and will look just like the FNP.

Locate it the same way by moving back until the **Target** appears in the center.

In Single Point, move back until the arrows point back.

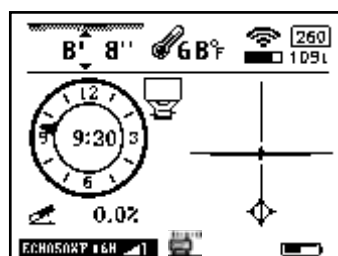
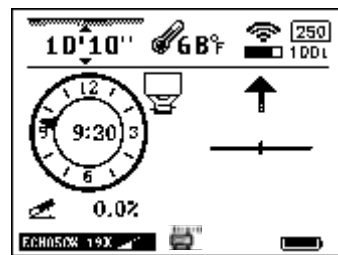
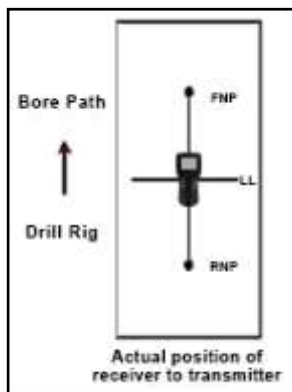



Locate Line (LL)

Then, imagine a line that runs through the FNP and RNP.

Locate the LL by walking along that line until the **LL Indicator** on the receiver screen enters the center. You are now above the LL, or head.

10.1.3: Tracking on the Fly

Tracking on the Fly is a simple process that will increase the speed at which the bore can be completed. Both the drill operator and locating operator can see the same screen in both modes, enabling minimal communication between operators.

1. Start out by drilling the first few rods in order to establish line and desired pitch.
2. Walk past the FNP by approximately 10', or one full length of rod.
(For more accurate left right sensitivity in Bore-To mode, always stay out front of the FNP.)
3. Place the locator on the desired bore path, pointing in the direction you want to go.
4. Press  to Activate Bore-To. (Press  again to return to Normal/Walkover.)
5. If the transmitter is pointing directly at your locator, you will see the **Distance to the Head** and the Target directly on the **Vertical Line** indicating you're heading directly to the locator.
6. Maintain pitch at the desired angle to show the correct **Predicted Depth** and **Depth over the Head**.

7. Keep the Target centered and you're on track to the receiver.

Depth is displayed in real time correcting for pitch changes giving both operators the ability to see the **Predicted Depth** of the head if drilled all the way to the receiver.

In **Figure 1**, the pitch is minus 5% meaning the calculated depth will be 12'4" when the transmitter arrives.

The head is 18' 1" behind the locator and headed slightly left of center.

To correct for the deviation, stop drilling and instruct the drill operator to rotate the drill rod to the appropriate clock and push until the Target is back on track with the vertical line.

Figure 1

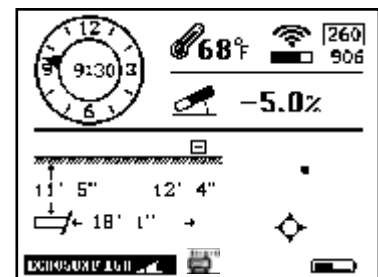

Single Target

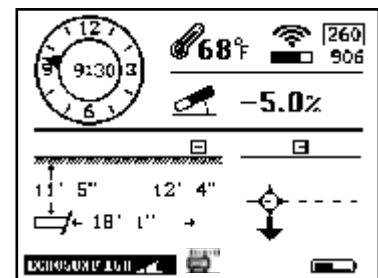

Single Point

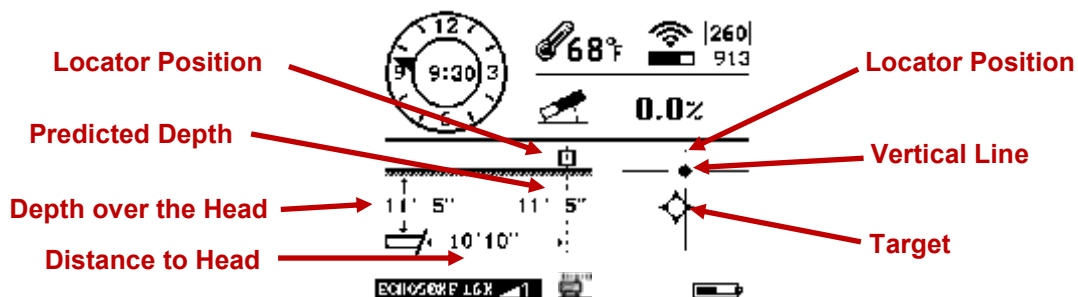

10.1.4: Bore-To

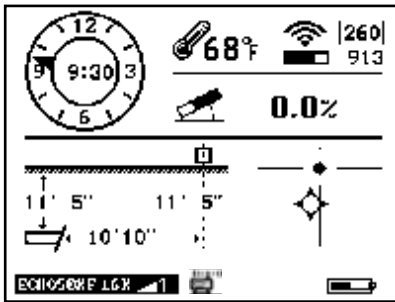

Single Target

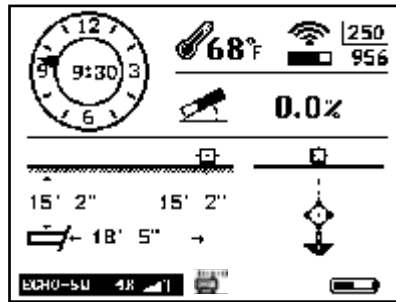

Single Point

The Bore-To feature on Mag systems is very powerful. Operators can expect to receive good right-left steering, pitch and roll information as far out as 100ft.

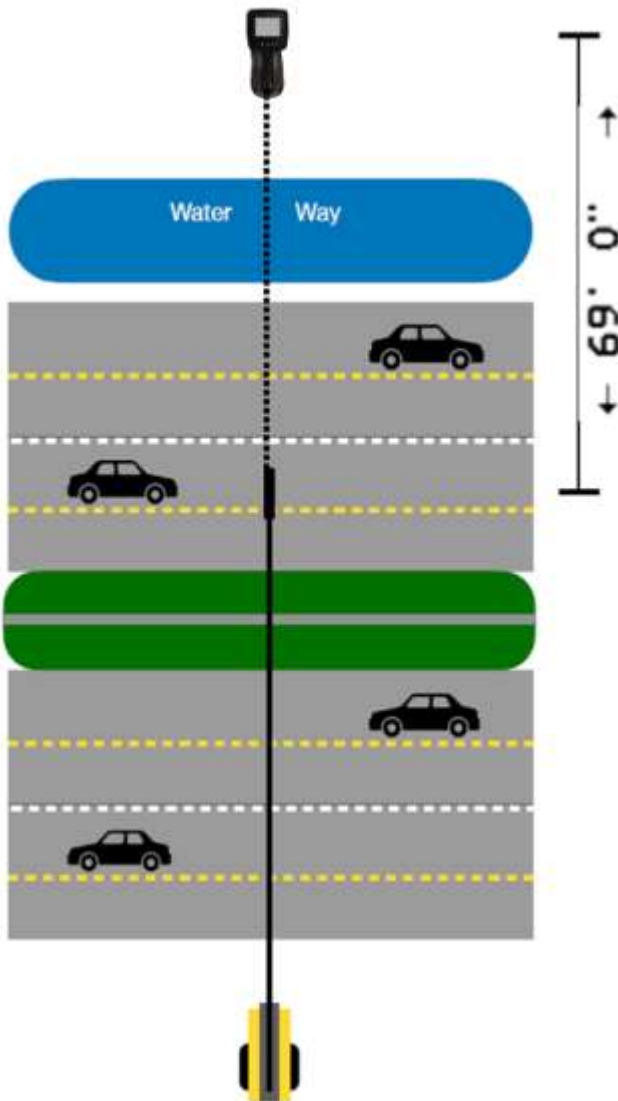

It is important to note that the depth is only a reference.

As distance between the transmitter and receiver decreases, the accuracy increases.

Never cross existing utilities while in Bore-To mode without exposing and verifying visually their location.

To switch the receiver to Bore-To mode, tap  from the main page.

To return to Walkover mode, simply tap  again.

The display screen on both the receiver and the remote display will look the same.

11: Battery and Charger

- ➔ Mag receivers use rechargeable lithium batteries.
- ➔ This lithium rechargeable battery comes with a special charger. Any use of other lithium rechargeable battery or charger for the receiver may cause fire, explosion, leaking or other damages.
- ➔ Store the battery at the room temperatures; 59-77° F (15-25° C). Extreme high or low temperatures will shorten the battery life.
 - Do not submerge the battery in water or any other liquids.
 - Do not throw the battery into fire.
 - Do not disassemble the battery.
 - Avoid any kind of damage to the battery.
 - Please dispose of lithium properly.
- ➔ When charging the battery, the red light will shine. When charging is complete, a green light will shine.

12: Warranty Policy

Underground Magnetics (UM) warrants that it will either repair or replace any product that fails to operate in conformity to UM's published specifications at the time of shipment due to a defect in materials or workmanship during the warranty period for that product, subject to the terms set forth below.

Warranty Period: All UM Transmitters, One year from date of purchase. Receivers, Remote Displays, Battery Chargers and Rechargeable Batteries (receiver and display) one year from the date of purchase. Software One year from date of purchase. Other Accessories Ninety days from date of purchase. Service/Repair Ninety days from date of repair. For software products, UM warrants that it will update any defective software to bring it into material compliance with UM's specifications for such software. The above warranties only apply to new products purchased directly from UM or from a UM authorized dealer. The ultimate determination of whether a product qualifies for warranty replacement shall be at UM's sole discretion. Exclusions: Transmitters that have exceeded the maximum temperature, as indicated by the system. Defect or damage caused by misuse, abuse, improper installation, improper storage or transport, neglect, accident, fire, flood, use of incorrect fuses, contact with high voltages or injurious substances, use of system components not manufactured or supplied by UM, failure to follow the operator's manual, use other than that for which the product was intended or other events beyond the control of UM. Any transmitter used with an improper housing, or damage caused to a transmitter from improper installation into or retrieval from a housing. Damage during shipment to UM. Any modification, opening, repair or attempted repair of a product, or any tampering or removal of any serial number, label or other identification of the product, will void the warranty. UM does not warrant or guarantee the accuracy or completeness of data generated by HDD locating systems. The accuracy or completeness of such data may be impacted by a variety of factors, including (without limitation) active or passive interference and other environmental conditions, failure to calibrate or use the device properly and other factors. UM also does not warrant or guarantee, and disclaims liability for, the accuracy and completeness of any data generated by any external source that may be displayed on a UM device, including (without limitation) data received from a drill rig. UM may make changes in design and improvements to products from time to time.

12: Warranty Policy continued

UM shall have no obligation to upgrade any previously manufactured UM product to include any such changes. THE FOREGOING IS THE SOLE WARRANTY FOR UM PRODUCTS. UM DISCLAIMS ALL OTHER WARRANTIES, EXPRESS OR IMPLIED, INCLUDING BUT NOT LIMITED TO IMPLIED WARRANTIES OF MERCHANTABILITY AND FITNESS FOR PARTICULAR PURPOSE. IMPLIED WARRANTY OF NON-INFRINGEMENT, AND ANY IMPLIED WARRANTY ARISING FROM THE COURSE OF PERFORMANCE, COURSE OF DEALING, OR USAGE OF TRADE, ALL OF WHICH ARE HEREBY DISCLAIMED. In no event shall UM or anyone else involved in the creation, production, sale or delivery of the UM product, including but not limited to indirect, special, incidental, or consequential damages, or for any cover, loss of information, profit, revenue or use, based upon any claim for breach of warranty, breach of contract, negligence, strict liability, or any other legal theory, even if Underground Magnetics has been advised of the possibility of such damages. In no event should Underground Magnetics or its partners' liability exceed the purchase price for the product.



Underground Magnetics

simple. powerful. affordable.

UMAGHDD.COM | 515.505.0960